

OPEN ACCESS

Positron bunching system for producing positronium clouds into vacuum

To cite this article: L Penasa *et al* 2014 *J. Phys.: Conf. Ser.* **505** 012031

View the [article online](#) for updates and enhancements.

Related content

- [Positron scattering from Biomolecules](#)
J R Machacek, W Tattersall, R A Boadle *et al.*
- [Quarter-Wave buncher for NICA project](#)
M Trushin, R Fatkullin, A Sitnikov *et al.*
- [Spin polarized low-energy positron source](#)
V N Petrov, S N Samarin, K Sudarshan *et al.*

Recent citations

- [The AEgIS experiment at CERN: measuring antihydrogen free-fall in earth's gravitational field to test WEP with antimatter](#)
R S Brusa *et al*
- [Laser excitation of the \$n=3\$ level of positronium for antihydrogen production](#)
S. Aghion *et al*

Positron bunching system for producing positronium clouds into vacuum

L Penasa¹, L Di Noto¹, M Bettonte¹, S Mariuzzi¹, G Nebbia² and R S Brusa¹

¹*Dipartimento di Fisica, Università di Trento and TIFPA-INFN, Via Sommarive 14, I-38123 Povo, Trento, Italy*

²*INFN Padova, Via Marzolo 8, 35131 Padova, Italy*

E-mail: luca.penasa@unitn.it

Abstract. A magnetic transport line, a magnetic field terminator and a positron buncher were designed and built to focus low-energy positron pulses from a Surko-type accumulator on a porous target. The 25 electrodes buncher, which produces a parabolic potential, was designed to implant 5 ns positron bunches with a spot of 3 mm into a target held at cryogenic temperature. These pulses will be used to obtain cooled Ps clouds into vacuum for laser excitation in spectroscopy experiments. By using high-voltage fast switches and a proper mu-metal shield the requirement to form Ps in a free (magnetic and electric) field region was satisfied compatibly with the request of injecting positrons at energies of 5-9 keV. The optical design, the electrical circuitry of the buncher and the construction solutions of the whole apparatus will be presented and explained.

1. Introduction

A new apparatus was designed and built in order to process pulses of $10^7 - 10^8$ positrons previously stored in a Surko-type accumulator every 100 seconds. Re-bunching and focusing these pulses on a nanochannelled Si sample [1] for producing cooled Ps into vacuum is the task of the system [2, 3]. Ps in vacuum will be used for spectroscopy experiments such as the excitation of Ps in the $n=3$ state and from $n=3$ to Rydberg states [4] in a free field region.

The apparatus will be connected, through a cross and a valve, to the first section of the AEGIS (Antimatter Experiment: gravity, Interferometry, Spectroscopy) positron transfer line that links the positron accumulator to the AEGIS main magnets. The apparatus will run for Ps studies during the down time of the AEGIS experiment [5], ie. when the antiproton are not supplied for the antihydrogen production.

The accumulator integrates at its end a parabolic potential buncher stage that can deliver positron pulses with a time width lower than 8 ns at an energy from 50 to 400 eV. Having to cross the first magnetic transport section of the AEGIS transfer line (~ 60 cm), the positron pulses reach the entrance of the new apparatus with about 15 ns time duration. The designed optics will allow to re-bunch the pulses to less than 5 ns in a spot of ~ 3 mm at the target position.

In section 2 an overview of the optics is given; in section 3 the electronic and mechanical design of the buncher is shown and explained, while in the final section 4 results of the electronic tests are reported.



2. Transport and focussing optics

The optical system of the apparatus can be divided into three different stages (see figure 1).

The first stage will extract the positron pulses transported through the AEGIS transfer line by a field of 0.1 T and inject them into the buncher (second stage). It is made by two magnetic coils and two electrodes. The coils, positioned at the two sides of the entrance valve, extend the magnetic field of the transfer line to a μ -metal electrode. This last, due to its proper shape, works as a magnetic field terminator reducing it from 0.1 T to 0.02 T in 5 mm. The μ -metal electrode (-500 V) with the second one (-1500 V) and the buncher-electrodes (held at -600 V) produce an electric field that focalizes the positrons in the middle of the buncher itself.

The buncher, second stage, is composed by 25 electrodes so that the buncher length becomes longer than the positron cloud length (~ 20 cm). When all positrons enter the buncher, a parabolic potential (2 kV amplitude) is applied between the first and the last electrode, in order to compress the positron bunches in space and time. In order to keep the target at ground potential and to give the positrons the desired energy, the parabolic function is superimposed to a bias voltage of 5-9 kV. The parabolic potential and the bias voltage are obtained by a HV pulse (10 kV) of 20-30 ns FWHM and a rise time of 4 ns.

The third stage is a lens, formed by a last electrode and the target kept at ground, which focalizes the positrons on the target at the desired energy (5-9 keV). In order to obtain a free electric field zone near the sample where Ps atoms are emitted, the last electrode is switched to ground potential in about 10 ns.

The apparatus (figure 2) will be shielded by a μ -metal box with double walls (1.5 mm thick) with a 1 cm gap in between. The magnetic field near the target region is expected to be < 2 gauss when the 5 T magnet of the AEGIS experiment is on.

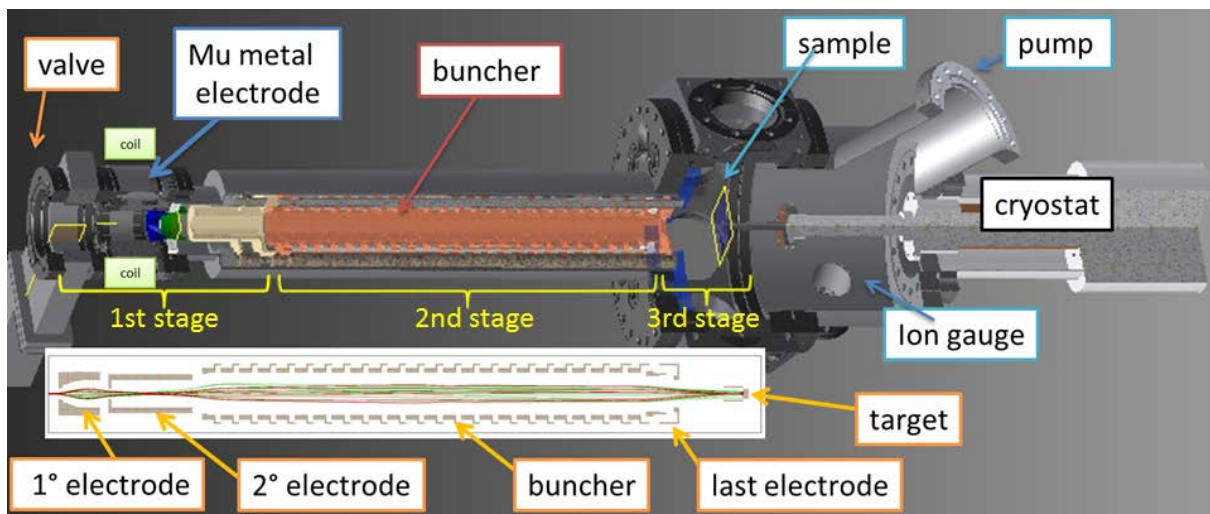

Figure 1. The apparatus layout and the simulation of the positrons trajectory. The simulation take into account the magnetic field distribution along the transfer line before the apparatus and both the static and the time varying potential of the optical system. Start positron pulse conditions at the output of the accumulator are: energy = $80\text{eV} \pm 10\%$, duration = 5 ns. Final conditions on the target are: energy = $8\text{keV} \pm 10\%$, pulse duration = 5ns, spot diameter = 3 mm.

3. The buncher design

The design must take into account mechanical and electrical constraints. The buncher length is 40 cm, the electrodes have an outer diameter of 56 mm and are inserted in a chamber of 100 mm inner diameter. With a 20-30 ns FWHM pulse and 4 ns rise time the buncher behaves as a transmission line. The chamber and the buncher are like a coaxial cable with a peculiar inner conductor. The mechanical

layout (resistors, chamber, electrodes, materials) establishes the characteristic parameters of the transmission line. In particular the design of the buncher takes into account the following parameters:

- the capacitance between electrodes must be as small as possible in order to have a high impedance for the HV pulse;
- the capacitance between the electrodes and the chamber must be small in order to have a high propagation velocity of the pulse;
- the ratio between the electrodes and the chamber diameters (ie. the outer conductor of the "coaxial line") must have the right value to match the buncher with the characteristic impedance of the system ($Z_0=75 \Omega$);
- the resistors between electrodes must have a small inductance ($L_r < 2-3 \text{ nH}$) to avoid electric oscillations;
- the total resistance of the buncher ($R_b=16 \text{ Ohm}$) must sustain the 120 A current to reach a 2 kV voltage drop.

In order to produce the parabolic potential, the electrodes of the buncher are connected to each other by proper resistors in such a way that the series of voltage drops generates the desired function. All resistors were realized with a gold electro-deposition on a high resistivity silicon support (figure 3) and then soldered on a kapton-gold strip with indium (figure 4). Three of these strips are wired to the electrodes along the buncher (figure 5). They are placed at 120° to reduce the magnetic field due to the high 120-130 A current flowing through them.

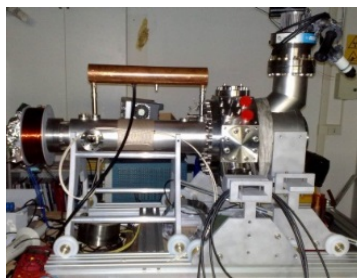

Figure 2. Apparatus

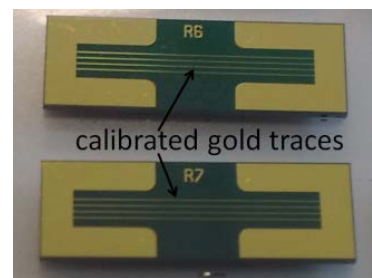

Figure 3. Resistors on Si support



Figure 4. Resistors soldered on kapton-gold strip

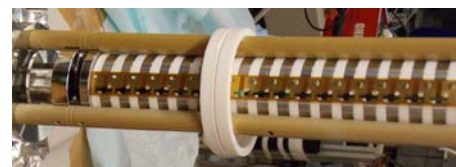

Figure 5. The buncher

It is important to notice that the superposition of the parabola and the bias is realized by using only one HV fast switch in a "voltage divider configuration", where an input resistor R_i and an output resistor R_o are used to change the bias voltage value and to match the load with the impedance of the system $Z_0=75 \Omega$. Different values of R_o correspond to different values of the bias potential of the buncher and different values of the positron energy on target. To keep the buncher network matched, the sum of R_i , R_o and R_b (total resistance of the buncher), must be equal to the characteristic impedance of the circuit Z_0 (figure 6).

In order to supply the buncher with a pulse of 10-11 kV with 120-130 A current and a fast rise time the solution we decided to use a fast switch produced by Behlke (HTS-12-150-UF). Due to its maximum operating voltage of 12 kV it is not possible to place at the output of the switch a resistance equal to the characteristic impedance of our network. In this configuration the buncher-system must be electrically matched with particular care since the switch cannot absorb a wave eventually reflected and moreover multi-reflected waves could distort the bunching of positrons. In order to avoid the

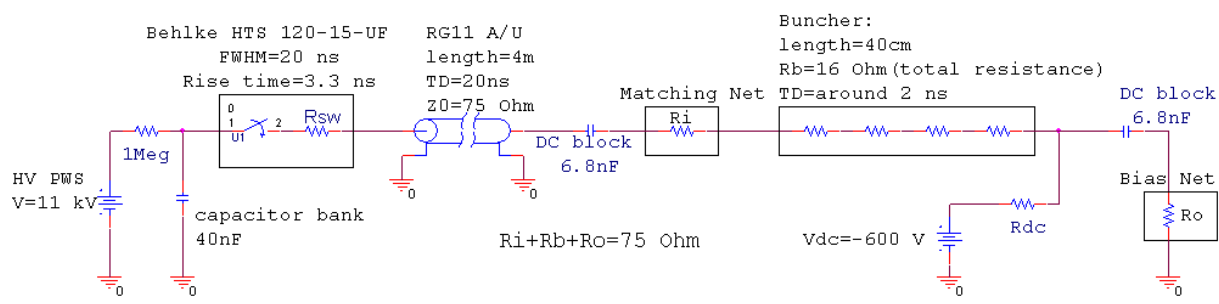

Figure 6. Electrical layout of the buncher system

problem of multiple reflections along the buncher a coaxial cable with Time Delay = 30 ns has been connected between the switch and the buncher.

To surge the high current, a HV capacitor bank of 40nF is placed before the switch. In order to verify the matching of the system, the shape of the pulses and the voltage drops between the resistors of the buncher, the electrical behavior of the system has been simulated with PSpice.

4. Results

Tests of the described system have been performed at different voltages setting $R_i=0\ \Omega$ and $R_o=59\ \Omega$. To check the voltage drop from the first to the last electrode of the buncher a low voltage pulse has been used (figure 7). We found, as desired, a voltage drop of 22% from the input to the output voltage which corresponds, at the nominal working condition, to about 2 kV. A test has been performed at 10 kV (figure 8) in order to verify that the resistors of the buncher can sustain the nominal current of the system (around 120 A). The difference between the supply voltage and the voltage amplitude of the pulses is due to the internal resistance of the switch ($R_s=10-15\ \Omega$).

The next series of tests are now planned at CERN using the real positron bunches delivered by the Surko-trap of the AEgIS experiment.

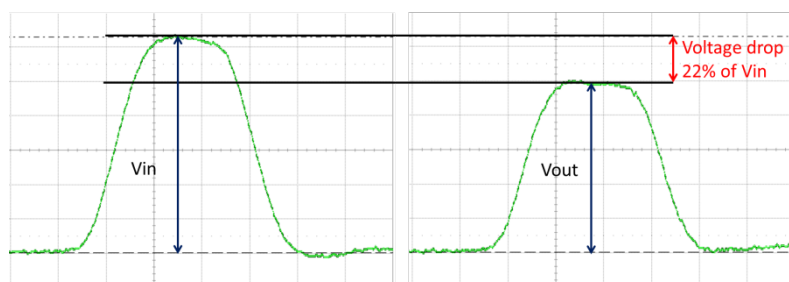

Figure 7. Test at low voltage. V_{in} is the voltage of the pulse measured on the first electrode of the buncher, V_{out} is the voltage measured on the last electrode.

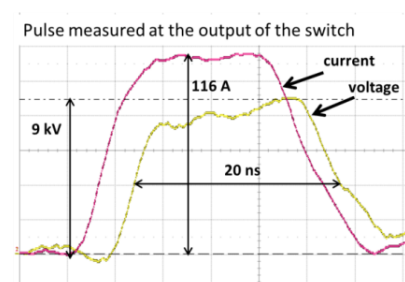

Figure 8. Test at 10 kV supply voltage

References

- [1] Mariazzi S, Bettotti P, Larcheri S, Toniutti L and Brusa R S 2010 *Phys. Rev. B* **81** 235418
- [2] Mariazzi S, Bettotti P and Brusa R S 2010 *Phys. Rev. Lett.* **104** 243401
- [3] Brusa R S and Dupasquier A 2010 *Positronium emission and cooling*, in *Physics with many Positrons*, Dupasquier A, Mills A P jr and Brusa R S eds, (North Holland, Amsterdam) p 245
- [4] Castelli F, Boscolo I, Cialdi S, Gianmarchi M, Comparat D 2008 *Phys. Rev. A* **78** 052512
- [5] A. Kellerbauer et al. *Nucl. Instr. Meth. Phys. Res.* 2008 B 266, 351-356