



(51) International Patent Classification:

F16F 15/03 (2006.01) F16F 15/02 (2006.01)
F16F 7/10 (2006.01) F16F 15/00 (2006.01)

(21) International Application Number:

PCT/GB2014/052002

(22) International Filing Date:

2 July 2014 (02.07.2014)

(25) Filing Language:

English

(26) Publication Language:

English

(30) Priority Data:

1312497.9 12 July 2013 (12.07.2013) GB
13275162.9 12 July 2013 (12.07.2013) EP

(71) Applicant: BAE SYSTEMS PLC [GB/GB]; 6 Carlton Gardens, London, SW1Y 5AD (GB).

(72) Inventors: DALEY, Stephen; University of Southampton, University Road, Southampton, Hampshire, SO17 1BJ (GB). ELLIOTT, Stephen, John; University of Southampton, University Road, Southampton, Hampshire, SO17 1BJ (GB). RUSTIGHI, Emiliano; University of Southampton, University Road, Southampton, Hampshire, SO17 1BJ (GB). ZILLETTL, Michelle; University of Southampton, University Road, Southampton, Hampshire, SO17 1BJ (GB).

(74) Agent: BAE SYSTEMS plc, Group IP Dept; PO Box 87, Farnborough Aerospace Centre, Farnborough, Hampshire, GU14 6YU (GB).

(81) Designated States (unless otherwise indicated, for every kind of national protection available): AE, AG, AL, AM, AO, AT, AU, AZ, BA, BB, BG, BH, BN, BR, BW, BY, BZ, CA, CH, CL, CN, CO, CR, CU, CZ, DE, DK, DM, DO, DZ, EC, EE, EG, ES, FI, GB, GD, GE, GH, GM, GT, HN, HR, HU, ID, IL, IN, IR, IS, JP, KE, KG, KN, KP, KR, KZ, LA, LC, LK, LR, LS, LT, LU, LY, MA, MD, ME, MG, MK, MN, MW, MX, MY, MZ, NA, NG, NI, NO, NZ, OM, PA, PE, PG, PH, PL, PT, QA, RO, RS, RU, RW, SA, SC, SD, SE, SG, SK, SL, SM, ST, SV, SY, TH, TJ, TM, TN, TR, TT, TZ, UA, UG, US, UZ, VC, VN, ZA, ZM, ZW.

(84) Designated States (unless otherwise indicated, for every kind of regional protection available): ARIPO (BW, GH, GM, KE, LR, LS, MW, MZ, NA, RW, SD, SL, SZ, TZ, UG, ZM, ZW), Eurasian (AM, AZ, BY, KG, KZ, RU, TJ, TM), European (AL, AT, BE, BG, CH, CY, CZ, DE, DK, EE, ES, FI, FR, GB, GR, HR, HU, IE, IS, IT, LT, LU, LV, MC, MK, MT, NL, NO, PL, PT, RO, RS, SE, SI, SK, SM, TR), OAPI (BF, BJ, CF, CG, CI, CM, GA, GN, GQ, GW, KM, ML, MR, NE, SN, TD, TG).

Published:

— with international search report (Art. 21(3))

(54) Title: IMPROVEMENTS IN AND RELATING TO VIBRATION CONTROL

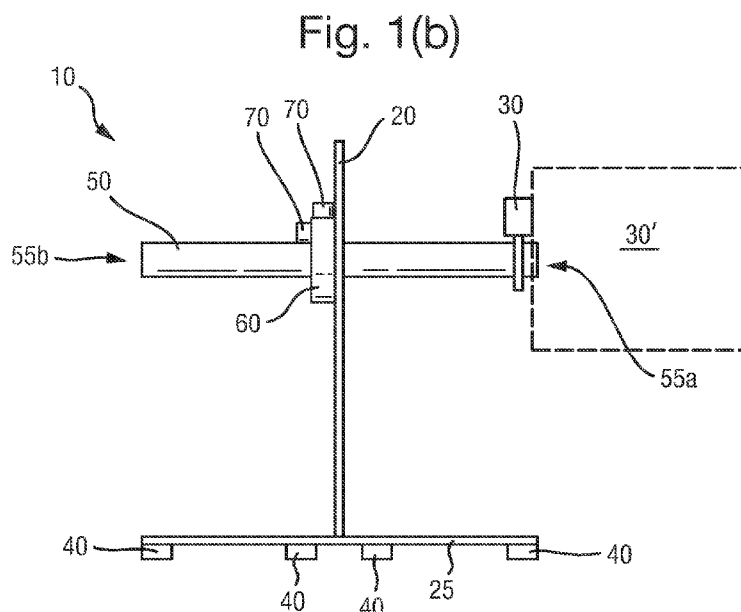

(57) Abstract: A machine (30) is on a first side of a plate (20) and a rod (50) passes along or through the plate (20). The plate (20) is susceptible to vibrations arising from operation of the machine (30). An active vibration suppressor (60) is mounted on the rod (50), and a controller is configured to control the active vibration suppressor (60) to suppress vibrations of the plate (20).



- 1 -

IMPROVEMENTS IN AND RELATING TO VIBRATION CONTROL**FIELD OF THE INVENTION**

This invention relates to the field of vibration control. More particularly,
5 the invention relates to active suppression of vibrations caused by machinery.
Still more particularly, but not exclusively, the invention relates to active
suppression of vibrations in vehicles, for example nautical vessels.

BACKGROUND ART

10 Machinery typically vibrates as it operates. The vibration can cause
problems, for example mechanical damage, reduced efficiency of operation,
increased noise and discomfort for persons in the vicinity of the machine. For
example, in a nautical vehicle such as a ship, excessive vibration from the
ship's engines can make travel in the ship uncomfortable.

15 It is known to use active machinery raft isolation mounts to control
vibrations resulting from the operation of machinery. However, machinery is
typically coupled to its environment in ways additional to the coupling through
the machinery's mounting, for example by flexible couplings associated with
exhaust, cooling, fuel and power supply systems. Such couplings and other
20 connections provide additional paths for vibrations to propagate from the
machinery, even if no vibrations were coupled across the mounts.

Wölfel Beratende Ingenieure GmbH + Co. KG produces an active
absorber (ADD.Pipe) for the reduction of vibrations in pipes in piping systems in
chemical plants and power plants. Vibrations in such systems are typically
25 caused by water or other liquid hammers, pressure pulses or other excitations.
The ADD.Pipe system is a collar that is clamped onto the piping system and
includes a sensor that measures vibrations in the pipe and linear actuators
actively controlled to move reaction masses to damp the vibrations in the pipe.
However, the system offers only limited control, and has the potential to suffer
30 from an effect known as pinning, in which vibration at the point of attachment of
the collar is reduced but becomes worse at points elsewhere in the pipeline.

- 2 -

It would be advantageous to provide an apparatus, including an active vibration suppressor, in which one or more of the aforementioned disadvantages is eliminated or at least reduced.

5

DISCLOSURE OF THE INVENTION

A first aspect of the invention provides an apparatus including a machine, a rod and a plate, wherein the machine is on a first side of the plate and at least part of the rod is on the second, opposite, side of the plate, and wherein the plate is susceptible to vibrations arising from operation of the machine,
10 CHARACTERISED BY an active vibration suppressor mounted on the rod, and a controller configured to control the active vibration suppressor to reduce vibrations of the plate.

It may be that the rod passes through the plate, from the first side of the plate to the second side of the plate.

15

It may be that the vibrations of the plate are minimised.

It may be that the machine is a source of motive force, for example an engine, for example an internal combustion engine, an electric motor or a turbine.

20

It may be that the rod is connected, for example directly connected, to the machine. It may be that the rod is driven by the machine. It may be that the rod is also susceptible to vibrations arising from operation of the machine.

25

It may be that the rod is a pipe. It may be that the rod is a cable or a bundle of cables. It may be that the rod is connected to or associated with the machine, for example it may be a pipe carrying a fluid to or from the machine (for example, fuel, coolant or exhaust) or a conduit carrying for example electrical power couplings.

It may be that the rod is flexible. Alternatively, it may be that the rod is rigid.

30

It may be that the plate is a flat plate. It may be that the plate is a curved plate.

- 3 -

It may be that the plate is a shell or a wall or a bulkhead.

It may be that the plate is or is part of a housing containing the machine. The housing may, for example, be a cuboidal housing, or a dome-shaped housing, or have another or a more complex shape. It may be that the plate
5 forms part of a wall of the housing: the first side of the plate will then be inside the housing and the second side of the plate will be outside the housing.

It may be that the plate is part of the machine itself, or is directly connected to the machine.

It may be that the rod or at least part of the rod is perpendicular to the
10 plate.

It may be that the rod or at least part of the rod is parallel to the plate.

It may be that the rod is rigidly connected to the plate.

It may be that the rod is resiliently connected to the plate

It may be that the rod is formed from a first part on the first side of the
15 plate and a second part on the second side of the plate, such that the first and second parts meet at the plate and are connected to each other and/or to the plate.

It may be that the active vibration suppressor is mounted on the rod on the second side of the plate, i.e. the opposite side from the machine.

It may be that the active vibration suppressor includes a collar that is
20 connected to and at least partially surrounds the circumference of the rod. It may be that the collar completely surrounds the circumference of the rod. It may be that the collar is integrated with the rod (i.e. they are monolithic). It may be that the collar is permanently fixed to the rod. It may be that the collar is
25 releasably fixed to the rod. It may be that the collar is moveable on the rod. It may be that the collar is positioned immediately adjacent to the plate.

It may be that the active vibration suppressor comprises a plurality of (for example 5) actuators arranged to act on the rod. It may be that the actuators act on the rod directly or it may be that the actuators act on the rod indirectly, for

- 4 -

example through the collar, if present. It may be that at least one of the actuators is arranged to act in a direction parallel to the length of the rod. It may be that there are three actuators, arranged to act on the rod in three orthogonal directions. It may be that two or more of the plurality of the actuators are
5 arranged to act on the rod the same direction, for example in a direction parallel to the length of the rod. For example, there may be three or more actuators arranged to act in a direction parallel to the length of the rod by acting on a first surface of a collar connected to and at least partially surrounding the rod, the first surface being perpendicular to the rod, and there may be two or more
10 further actuators arranged to act in two directions orthogonal to the length of the rod and each other by acting on the collar on a surface perpendicular to the first surface. It may be that the plurality of actuators includes one or more actuators arranged to apply a bending moment to the rod. It may be that the plurality of actuators includes two or more actuators arranged to apply orthogonal bending
15 moments to the rod. It may be that the plurality of actuators includes one or more actuators arranged to apply radial forces to induce compression in the rod; advantageously, the rod may be a pipe arranged to carry a flow and the controller may be configured to control that one or more actuator to suppress flow noise in the pipe.

20 The actuators may be magnetostrictive actuators. The actuators may be voice-coil activators. The actuators may be piezo-electric devices.

The apparatus may further comprises a plurality of sensors arranged to sense vibrations of the plate and to generate a signal indicative of those vibrations. The sensors may for example measure the velocity of the plate at
25 the location of the sensor. The controller may be configured to receive the generated signal and to use it to determine a control signal to be generated and applied to the actuators to suppress vibrations of the plate. The controller may be configured to suppress vibrations of the plate by minimising a parameter derived from the signal from the sensors, for example minimising the sum of
30 mean squared velocities measured by the sensors. The controller may be configured to control three degrees of freedom of movement of the plate, for example movement in three orthogonal directions, two in the plane of the plate

- 5 -

and the third perpendicular to the plate, or one perpendicular to the plate and moments about two perpendicular axes in the plane of the plate. The controller may be configured to control five degrees of freedom of movement of the plate, for example movement in three orthogonal directions, two in the plane of the plate and the third perpendicular to the plate, and moments about two perpendicular axes in the plane of the plate. It may be that there is the same number of actuators as there are degrees of freedom of movement controlled by the controller.

It may be that the controller is configured to control the active vibration suppressor also to reduce vibrations of a further part of the apparatus, for example a part of the rod or another rod included in the apparatus. The apparatus may then further comprise a plurality of sensors arranged to sense vibrations of the further part of the apparatus and to generate a signal indicative of those vibrations. The sensors may for example measure the velocity of the further part at the location of the sensor. The controller may be configured to receive the generated signal and to use it to determine a control signal to be generated and applied to the actuators to suppress vibrations of the further part. The controller may be configured to suppress vibrations of the further part by minimising a parameter derived from the signal from the sensors, for example minimising the sum of mean squared velocities measured by the sensors. The controller may be configured to control three degrees of freedom of movement of the further part, for example movement in three orthogonal directions. The controller may be configured to control five degrees of freedom of movement of the further part, for example movement in three orthogonal directions and moments about two perpendicular axes. It may be that there is the same number of actuators as there are degrees of freedom of movement controlled by the controller.

A second aspect of the invention provides a method of suppressing vibrations arising from operation of a machine, wherein the machine is part of an apparatus also including a rod and a plate, the machine being on a first side of the plate and at least part of the rod being on the second, opposite, side of the plate, the plate being susceptible to vibrations arising from operation of the

- 6 -

machine, the method comprising applying an actively controlled force to the rod to reduce vibrations of the plate.

A third aspect of the invention provides vibration suppression equipment suitable for use in reducing vibrations in an apparatus comprising a machine, a rod and a plate, the equipment comprising:

- (i) an active vibration suppressor, adapted to be mounted on the rod; and
- (ii) a controller configured to control the active vibration suppressor to reduce vibrations of the plate.

It will of course be appreciated that features described in relation to one aspect of the present invention may be incorporated into other aspects of the present invention. For example, the method of the invention may incorporate any of the features described with reference to the apparatus of the invention and *vice versa*.

15

BRIEF DESCRIPTION OF THE DRAWINGS

Example embodiments of the invention will now be described by way of example only and with reference to the accompanying drawings, of which:

Figure 1 is an apparatus that is an example embodiment of the invention, shown in (a) front elevation and (b) side elevation;

Figure 2 is a front elevation of a collar from the apparatus of Fig. 1;

Figure 3 is a plot, against frequency in Hertz, of power in Watts input into the plate of the apparatus of Fig. 1 in a simulation, without control (solid line), when the power input into the plate is minimised using three vertical (i.e. z-axis, parallel to the beam) control forces (dashed line) and using three vertical control forces and two horizontal (i.e. parallel to the plate) control forces (dotted line), all acting on the plate;

Figure 4 is a plot, against frequency in Hertz, of power in Watts input into the plate of the apparatus of Fig. 1 in a simulation, without control (solid line)

- 7 -

when the power input into the plate (dashed line) is minimised and also when the sum of the velocity squared, measured using 3 sensors located on the plate, is minimised (dotted line), where the controller consists of three forces acting on the beam at 3 cm from the plate;

5 Figure 5 is a plot, against frequency in Hertz, of power in Watts input into the plate of the apparatus of Fig. 1 in a simulation, without control (solid line) when the power input into the plate (dashed line) is minimised and also when the sum of the velocity squared, measured using 3 sensors located on the plate, is minimised (dotted line), where the controller consists of a vertical force and
10 two moments acting on the beam at 3 cm from the plate;

 Figure 6 is a plot, against frequency in Hertz, of the sum of the mean squared value of the velocities along the z-axis measured by five monitoring sensors in a simulation, without control (solid line) when the power input into the plate is minimised (dashed line) and when the sum of the mean squared value
15 of the velocities measured by three error sensors is minimised (dotted-line), for the same conditions as were used to generate Fig. 5;

 Figure 7 is a plot, against frequency in Hertz, of the sum of the mean squared value of the velocities in the z-direction measured by (a) the monitor sensors and (b) the error sensors before control (solid line) and after control
20 (dashed line), in a simulation employing transfer functions measured on the apparatus of Figs. 1 and 2, and in which three actuators apply a common vertical force and two further actuators apply horizontal forces;

 Figure 8 is a plot, against frequency in Hertz, of the sum of the mean squared velocities in z-direction measured by (a) the monitor sensors and (b)
25 the error sensors before control (solid line) and after control (dashed line), in a simulation identical to that used to generate Fig. 7, but in which three actuators apply three independent vertical forces and two further actuators apply horizontal forces; and

 Figure 9 is a plot of the power spectral density (PSD) of the sum of the
30 accelerations measured by the three error sensors without control (predominantly upper line) and with control (predominantly lower line), along the

- 8 -

(a) x axis, (b) y-axis and (c) z-axis, obtained by experiment with the apparatus of Figs. 1 and 2 being driven at 447Hz.

DETAILED DESCRIPTION

5 An example embodiment of the invention was created as an experimental test apparatus 10 (Fig. 1(a) and (b)). The test apparatus 10 includes a cantilever plate 20 supported on a base sheet 25. The base sheet 25 is mounted on a plurality of isolation mounts 40, which act to isolate the plate 20 from environmental vibrations, to improve the accuracy of the testing. The
10 cantilever plate 20 is coupled with a pipe 50 having its axis perpendicular to the plate 20. The pipe 50 is free at both of its ends 55a, 55b. The pipe 50 passes through a hole in the plate 20, the hole being off-centre, offset towards the top and side of the plate 20.

An active vibration suppressor including a moveable collar 60 is mounted
15 on the pipe 50, on the side of the plate 20 towards the left-hand end 55b of the pipe 50, as shown in Fig. 1(b). In this experiment, the collar 60 was mounted so that it abutted the plate 20. The collar 60 carried a plurality of actuators 70.

Vibrations were excited in the plate 20 and pipe 50 using a primary
20 actuator (shaker) 30, mounted on the pipe 50, on the opposite side of the plate 20, close to the opposite end 55a of the pipe 50. This shaker 30 was used to excite vibrations representing the vibrations that would be excited by a machine 30' connected to the end 55a of the pipe 50.

The collar 60 and actuators 70 are shown in more detail in Fig. 2. The
25 collar 60 is a steel annulus 80, approximately 20 cm in diameter with a central circular hole 9 cm in diameter. The annulus 80 is of rectangular cross-section, having flat front and rear surfaces and flat inner and outer walls. Five actuators 70a-e are mounted on the annulus 80: three are mounted on the front surface and two on the outer wall. The three actuators 70a-c mounted on the front surface of the annulus 80 are spaced equidistantly around the annulus, i.e.
30 separated by 120 degrees. These three actuators 70a-c act in a direction perpendicular to the plane of the annulus 80, i.e. parallel to the axis of the pipe

- 9 -

50 when the collar is in use. The other two actuators 70d,e, mounted on the outer wall of the annulus, act in directions perpendicular to the plane of the annulus 80 and perpendicular to each other. Thus the three actuators 70a-c on the front surface, on the one hand, and the two actuators 70d,e on the outer wall on the other hand together provide actuation in three orthogonal directions.

A computer model of a beam was used to represent the plate 20 and pipe 30, with the beam having the same length and second moment of area as the pipe 30. The geometrical and physical parameters of the system are summarised in Table 1.

10 Table 1

Parameter	Value
PIPE	
Diameter of the pipe cross section	$D=89.9 \times 10^{-3} \text{ m}$
Thickness of the pipe	$s=5 \times 10^{-3} \text{ m}$
Length of the pipe	$l=1 \text{ m}$
Mass of the pipe	$M_{\text{pipe}}=5.3 \text{ Kg}$
PLATE	
Plate's edges	$(l_x, l_y)=(1, 1) \text{ m}$
Thickness	$h=20 \times 10^{-3} \text{ m}$
Intersection between the plate and beam	$(b_x, b_y)=(375 \times 10^{-3}, 1.125 \times 10^{-3}) \text{ mm}$
Mass of the plate	$M_p=155 \text{ Kg}$
MATERIAL STEEL	
Density	$\rho=7750 \text{ Kg/m}^3$
Young Modulus	$E=200 \times 10^9 \text{ N/m}^2$
Poisson's coefficient	$\nu=0.33$

When the model of the system is excited at the end of the beam corresponding to the end 55a of the pipe 50 by three in-phase forces along each of the three main directions, resonances are clearly evident, in both the beam and the plate.

In the simulations, 285 modes of the flexural vibration of the plate and 15 modes of the in-plane vibration of the plate, the flexural vibration of the beam and axial vibration of the beam were included. In order to gain a better understanding of the dynamics of the system the velocities in the z direction at

- 10 -

1156 points scattered on the plate were calculated when the system was excited at frequencies that coincide with the first few resonances of the system.

Simulations were carried out both of the case in which the active vibration suppressor is placed on the plate 20 and the case in which it is placed on the pipe 50.

In the first simulation, a feed-forward control strategy was selected to minimise the power input into the plate, using multiple actuators located on the plate, adjacent to and surrounding the beam. Three control forces were provided in the z direction (parallel to the pipe) and two control forces along the x and y directions. Fig. 3 shows the power input into the plate without control (black line), when the controller is optimised to minimise the power input into the plate at each frequency when only three vertical forces are used (dashed line), and when five control forces (three vertical and two horizontal) are used (dotted line). The best reduction of the power input into the plate is obtained at low frequency when the wavelength is much bigger than the distance between the secondary sources and the intersection point between the plate and the beam. The plot shows that the use of two extra control forces in x and y directions allows the system to achieve some control even at the in-plane resonance frequency of 1800 Hz.

For simulation of the arrangement in which the control sources are placed on the pipe 50, the actuators were located in the model on the beam at 3 cm from the plate, on the unexcited side of the beam.

From a practical point of view, measurement of the power input into the plate 20 would be difficult to implement. An alternative and more practical control strategy is to measure the velocities at a number of points on the plate 20 and thus to minimise the sum of the mean squared velocities.

Three different configurations of the control system were simulated. In the first configuration a force acting along the axis of the beam and two forces along the x and y axis are used as secondary sources. In the second configuration a force acting along the axis of the beam and two moments

- 11 -

around the x and y axes are used as secondary sources. In the last case three forces and two moments acting on the beam are used as secondary sources.

The model included three error sensors placed on the plate 20, around the pipe 50. The distance between the axis of the pipe 20 and the error sensor was 20 cm. There were also five monitoring sensors positioned on the plate 20, which could measure the velocity along the z-axis only (this constraint was used to represent the experimental facility). The purpose of the monitoring sensors was to obtain an indication of the global response of the plate 20 when control is applied.

For the first configuration, Fig. 4 shows the modelled power input into the plate without control (solid line), when the optimal controller that minimises the power input into the plate is implemented (dashed line) and when the sum of the velocities squared measured by three error sensors is minimised (dotted line). The three error sensors are able to measure the velocity along the three principal axis x, y, and z. Figure 4 shows that minimising the sum of the mean squared velocities measured by the three error sensors closely corresponds to the minimisation of the power input of the plate at low frequency, although at higher frequency less reduction in the power input into the plate is obtained in this example when the sum of the mean squared velocities is minimised.

The second configuration simulates a vertical force along the z-axis (i.e. along the pipe 50) and two moments around the x- and y-axes acting on the pipe 50. Fig. 5 shows the modelled power input into the plate without control (solid line), when the optimal controller that minimises the power input into the plate is implemented (dashed line) and when the sum of the velocities squared measured by three error sensors is minimised (dotted line). The plot shows that in this case the two control strategies give very similar reduction in the power input into the plate. Moreover, for this case, a vastly superior reduction compared with the previous case of three secondary forces was achieved. The two peaks that appear around 1.2 and 1.8 kHz are due to flexural vibration of the beam.

- 12 -

Fig. 6 shows the sum of the mean squared velocities measured by the five monitoring sensors without control (solid line), when the power input into the plate is minimised (dashed line), and when the mean squared velocity measured by the three error sensors is minimised (dotted line). The plot shows that excellent overall reduction in the vibration of the plate can be achieved using both control strategies up to about 1.8 kHz.

Further simulation results have shown that in the third configuration (i.e. with three secondary forces acting along the x, y and z axes and two moments around the x- and y-axes) in theory both the power injected into the plate, and the sum of the mean squared velocities are perfectly controlled; they are not reproduced here since the results tend to zero.

We now return to the experimental apparatus 10 of Fig. 1. The five actuators 70a-e on the collar 60 are each inertial electromagnetic actuators. As discussed above, actuators 70a-c generate a force perpendicular to the plate 20 while actuators 70d and 70e produce forces along the other two principal directions. The collar 60 can be rotated and moved along the pipe 50; however, in the experimental results presented below the collar 60 is positioned as close as possible to the plate 20. As in the simulations, three accelerometers (not shown) are used as error sensors for control purposes; they are able to measure the acceleration along the three principal axes. Four single axis accelerometers (not shown) were also placed on the plate 20 in order to monitor the global response. The primary disturbance excitation was provided using a Data Physics IV 40 inertial actuator (shaker) 30 located near the tip 55a of the pipe 50. That primary shaker 30 is also mounted on a collar which enables a variety of disturbances to be effected, by mounting the shaker 30 in different orientations.

Before attempting real-time control the level of performance achievable with this arrangement was assessed. For this purpose the transfer functions from, on the one hand, the primary source 30 and the actuators 70 to, on the other hand, all the sensors mounted on the plate 20 were measured. Those measured transfer functions were then used in further simulations to predict the behaviour of the system when different harmonic control strategies were

- 13 -

implemented. The measured transfer functions were also used for the identification of the system required to implement real time control. All the transfer functions between the primary actuator 30 and secondary actuators 70 and the error and monitor sensors were measured using a twenty channel
5 analyser (Data Physics Mobilyzer II). Although the transfer functions between the primary shaker 30 and the sensors have been measured for 4 different orientations of the primary actuator, only the results when the primary force forms an angle of about 45 degrees with each of the principal axis are presented here.

10 Fig. 7 shows the modelled sum of the mean squared monitor velocities (plot (a)) and error velocities (plot (b)) without control (solid line) and when the optimal simulated control is implemented (dashed line). In this example, actuators 70a-c were driven with the same signal to minimise the sum of the three mean squared velocities measured by the three error sensors along z-
15 axis. Actuators 70d,e were driven with two different signals to minimise the sum of the mean squared velocities in x- and y-axes respectively. In this configuration, the controller 75 applies three orthogonal forces aligned with the principal axes near the point of intersection of the pipe 50 and plate 20 and so is not able to produce moments to control vibration arising from this mode of
20 excitation. Nevertheless, the plots show that significant reduction in excess of 40dB across a broad range of frequencies can be achieved by implementing this type of control. The resonance of the primary shaker is about 30 Hz, therefore at lower frequencies the structure cannot be efficiently excited. The resonance of the secondary actuators 70 is about 55 Hz therefore control will
25 not be effective at frequencies significantly below this.

A much better broadband reduction can be achieved when the five secondary actuators 70a-e are driven independently to minimise the sum of the mean squared velocities measured by the three error sensors. For this case the controller 75 is able to produce three orthogonal forces and two moments. Fig.
30 8 shows the modelled sum of the mean squared monitor velocities (plot (a)) and error velocities (plot (b)) without control (solid line) and when the optimal simulated control is implemented (dashed line).

- 14 -

A comparison between Fig. 7 and Fig. 8 clearly shows that the most efficient control strategy is that used to produce the latter plot, i.e. one able to generate moments and forces as already predicted by the simulation results from the beam-plate model. It will be noted that the results indicate that a mean
5 reduction in the region of 50dB is achievable across a very broad band of frequencies. For some specific frequencies however, notably around 390Hz, the reduction is not as great. However, that this is not significant since that frequency corresponds to a structural mode that is not strongly excited by the pipe excitation and could be tackled with a different distribution of error sensors.

10 Finally, some preliminary experimental results that demonstrate the performance and potential of the control system are presented. In this experimental work, a controller 75 with only three degrees of freedom was used, i.e. where the three secondary actuators 70 a-c on the front face of the annulus 80 were each driven using the same signal to minimise the sum of the
15 mean squared accelerations measured by the corresponding three error sensors in the z direction and the actuators 70d,e on the side of the annulus 80 were driven with two different signals to minimise the sum of the mean squared accelerations along the x- and y- axes respectively. This limited structure was used due to programme time constraints and the immediate availability of
20 suitable control software. The harmonic controller 75 was implemented in feedback mode and the disturbance path is therefore assumed to be unknown. The primary disturbance shaker 30 was driven with a sinusoidal signal of 447 Hz and oriented to form an angle of 45 degrees with the three principal axes.

Fig. 9 (a)-(c) shows the PSD of the sum of the accelerations measured
25 by the three error sensors along x, y and z-axis respectively without control (blue line) and with control (red line). An iterative frequency domain algorithm was used for the control strategy; however, in the time available a rigorous search for the optimal parameters was not possible and so these results do not represent the true optimum performance for this configuration. Nevertheless,
30 and despite the limited control authority, the plots show that the error signals at the excitation frequency of 447 Hz are reduced by 17.3, 17.2 and 32.5 dB

- 15 -

respectively. That clearly demonstrates the validity of the theoretical results above and underlines the enormous potential of the approach.

Thus we have shown that an active approach can be used to reduce the levels of plate vibration caused by the solid penetration of a vibrating pipe by several orders of magnitude. The best achievable performance of those
5 investigated here was shown to be obtained by applying controlled forces and moments to the pipe using an actuation system with five degrees of freedom. In simulation work based on a rigorous mobility analysis a mean suppression in the region of 50dB was shown to be theoretically achievable for a generic
10 interacting plate-pipe system. An actuated pipe collar having the necessary five degrees of freedom was developed and a prototype system was built and trialled using a purpose built laboratory scale test rig. This system was tested under constrained operation, but despite that achieved reductions in an acoustically radiating structural mode of over 30dB. Use of a collar carrying the
15 actuators has the particular benefit that a high level of vibration suppression can potentially be achieved for all transmission paths that propagate from a given isolation system (e.g. across flexible couplings associated with exhaust, cooling, fuel and power supply systems), and not merely those propagating through the system's mounting.

20 Whilst the present invention has been described and illustrated with reference to particular embodiments, it will be appreciated by those of ordinary skill in the art that the invention lends itself to many different variations not specifically illustrated herein.

Where in the foregoing description, integers or elements are mentioned
25 which have known, obvious or foreseeable equivalents, then such equivalents are herein incorporated as if individually set forth. Reference should be made to the claims for determining the true scope of the present invention, which should be construed so as to encompass any such equivalents. It will also be appreciated by the reader that integers or features of the invention that are
30 described as preferable, advantageous, convenient or the like are optional and do not limit the scope of the independent claims. Moreover, it is to be

- 16 -

understood that such optional integers or features, whilst of possible benefit in some embodiments of the invention, may be absent in other embodiments.

- 17 -

CLAIMS

1. An apparatus including a machine, a rod and a plate, wherein the machine is on a first side of the plate and at least part of the rod is on the second, opposite, side of the plate, and wherein the plate is susceptible to vibrations arising from operation of the machine, CHARACTERISED BY an active vibration suppressor mounted on the rod, and a controller configured to control the active vibration suppressor to reduce vibrations of the plate.
5
- 10 2. An apparatus as claimed in claim 1, in which the rod passes through the plate, from the first side of the plate to the second side of the plate.
3. An apparatus as claimed in claim 1 or claim 2, wherein the rod is connected to the machine.
4. An apparatus as claimed in any preceding claim, wherein the rod is a pipe.
- 15 5. An apparatus as claimed in any preceding claim, wherein the plate is or is part of a housing containing the machine.
6. An apparatus as claimed in any of claims 1 to 4, wherein the plate is part of the machine itself, or is directly connected to the machine.
7. An apparatus as claimed in any preceding claim, wherein the active vibration suppressor is mounted on the rod on the second side of the plate.
20
8. An apparatus as claimed in any preceding claim, wherein the active vibration suppressor comprises a plurality of actuators arranged to act on the rod.
- 25 9. An apparatus as claimed in any preceding claim, wherein the active vibration suppressor includes a collar that is connected to and at least partially surrounds the circumference of the rod.

- 18 -

10. An apparatus as claimed in claim 9, wherein three or more actuators are arranged to act in a direction parallel to the length of the rod by acting on a first surface of the collar, the first surface being perpendicular to the rod, and two or more further actuators arranged to act in two directions, orthogonal to the length of the rod and each other, by acting on the collar on a surface perpendicular to the first surface.
11. An apparatus as claimed in any preceding claim, further comprising a plurality of sensors arranged to sense vibrations of the plate and to generate a signal indicative of those vibrations.
12. An apparatus as claimed in claim 11, wherein the controller is configured to suppress vibrations of the plate by minimising a parameter derived from the signal from the sensors.
13. An apparatus as claimed in claim 12, wherein the parameter is the sum of mean squared velocities measured by the sensors.
14. A method of suppressing vibrations arising from operation of a machine, wherein the machine is part of an apparatus also including a rod and a plate, the machine being on a first side of the plate and at least part of the rod being on the second, opposite side of the plate, the plate being susceptible to vibrations arising from operation of the machine, the method comprising applying an actively controlled force to the rod to reduce vibrations of the plate.
15. Vibration suppression equipment suitable for use in reducing vibrations in an apparatus comprising a machine, a rod and a plate, the equipment comprising:
- (i) an active vibration suppressor, adapted to be mounted on the rod; and
 - (ii) a controller configured to control the active vibration suppressor to reduce vibrations of the plate.

Fig. 1(a)

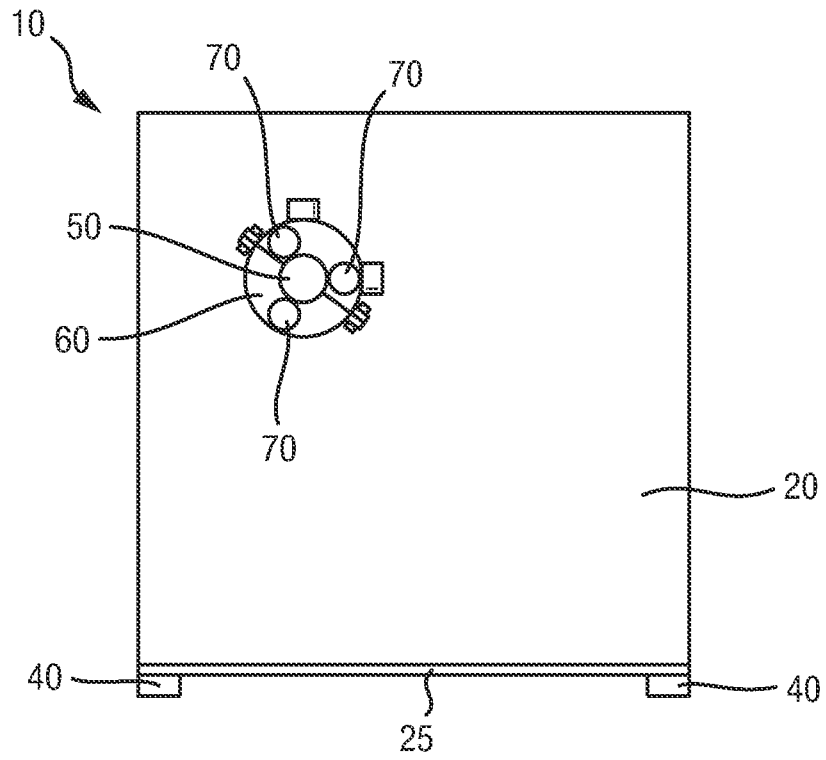

Fig. 1(b)

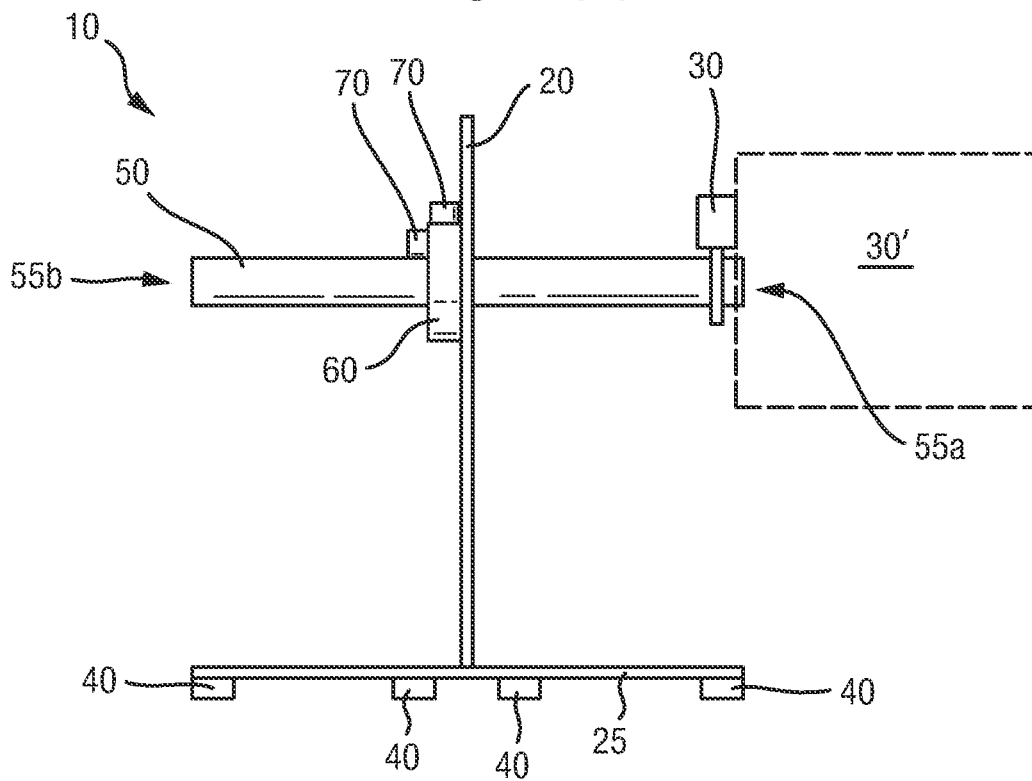

Fig. 2

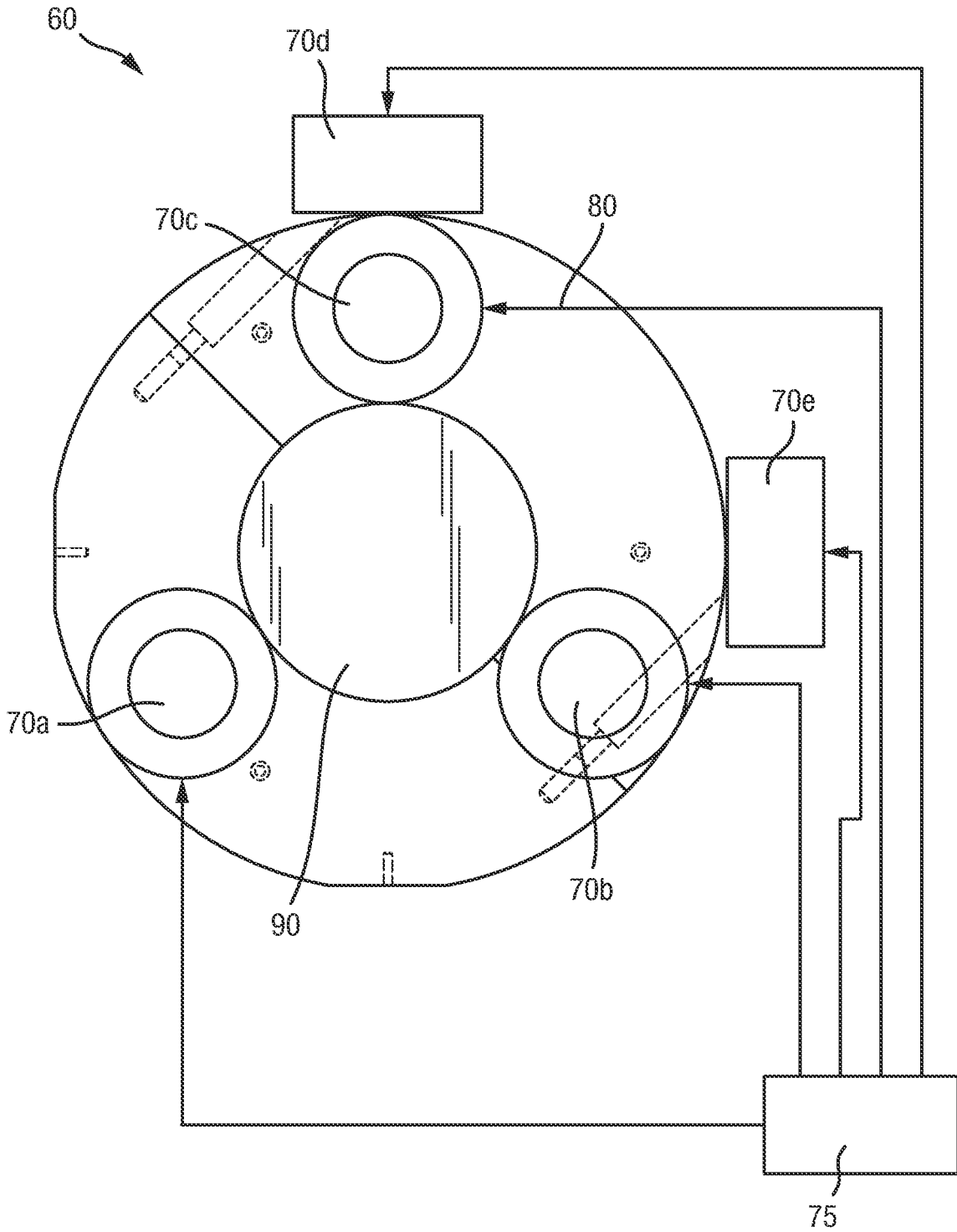

Fig. 3

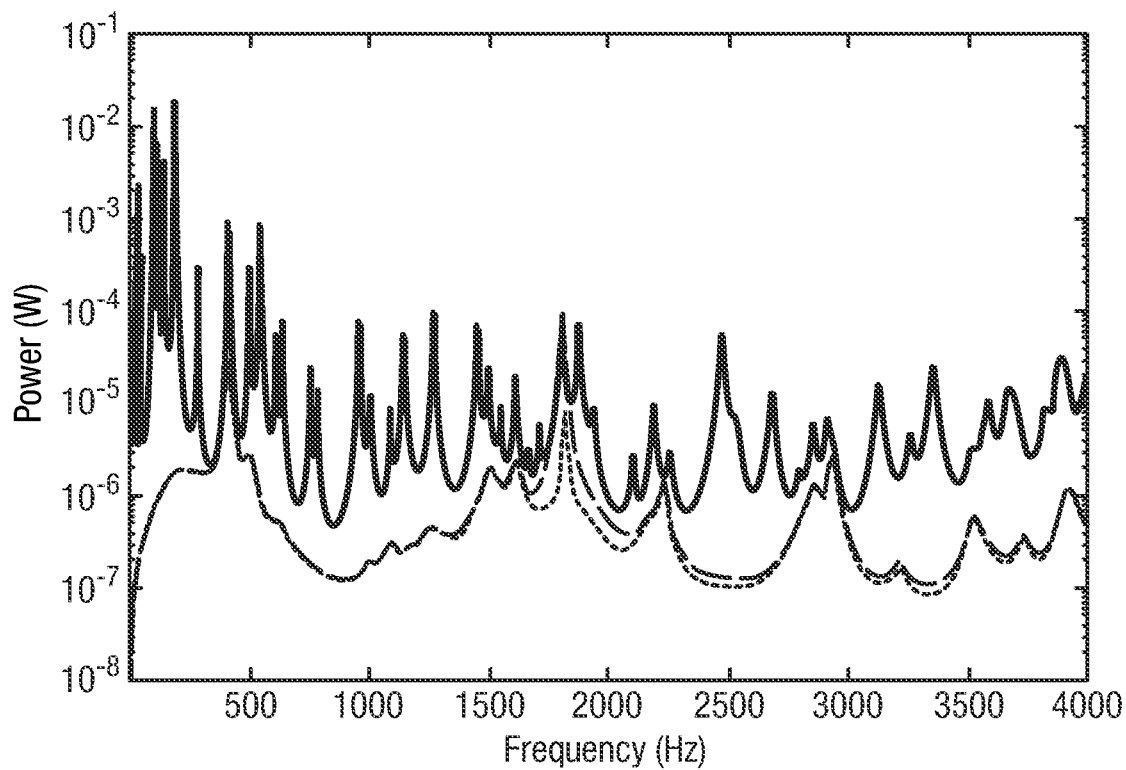

Fig. 4

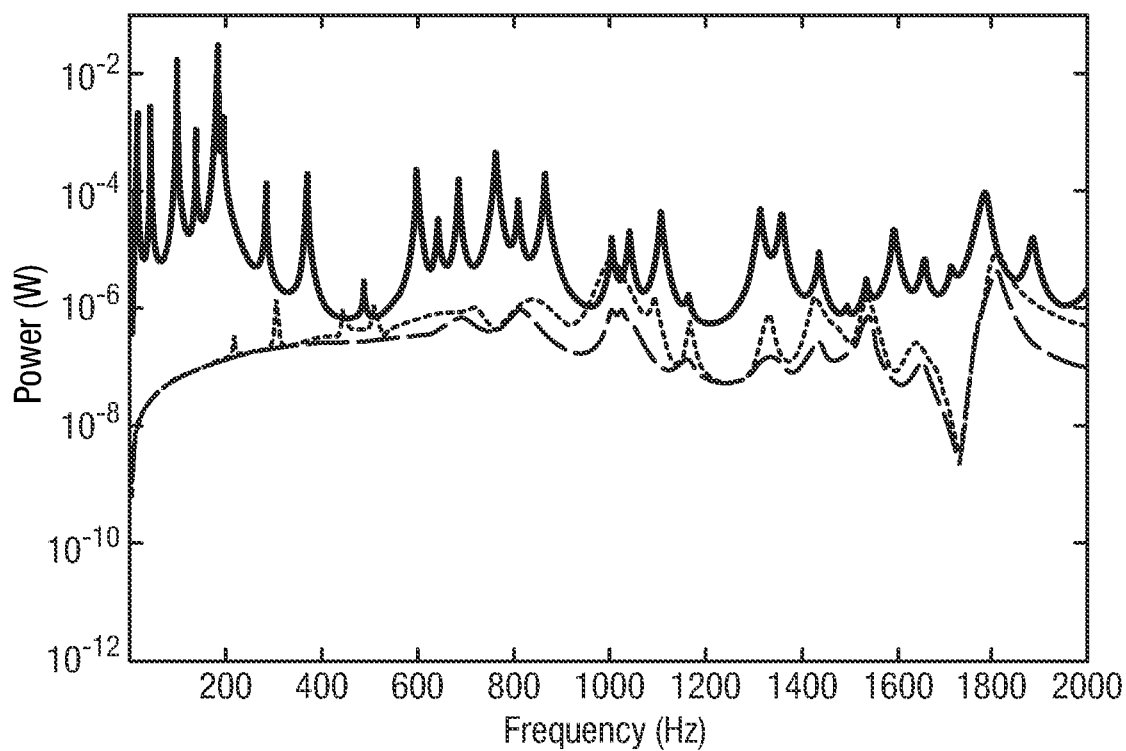

Fig. 5

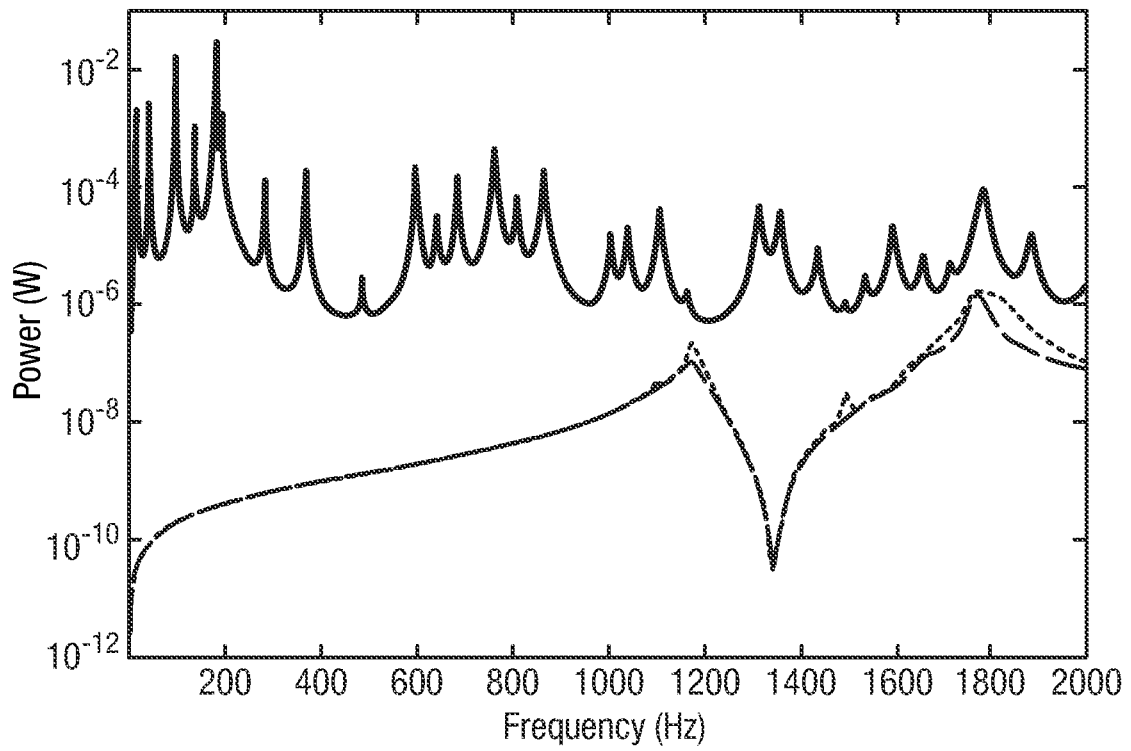

Fig. 6

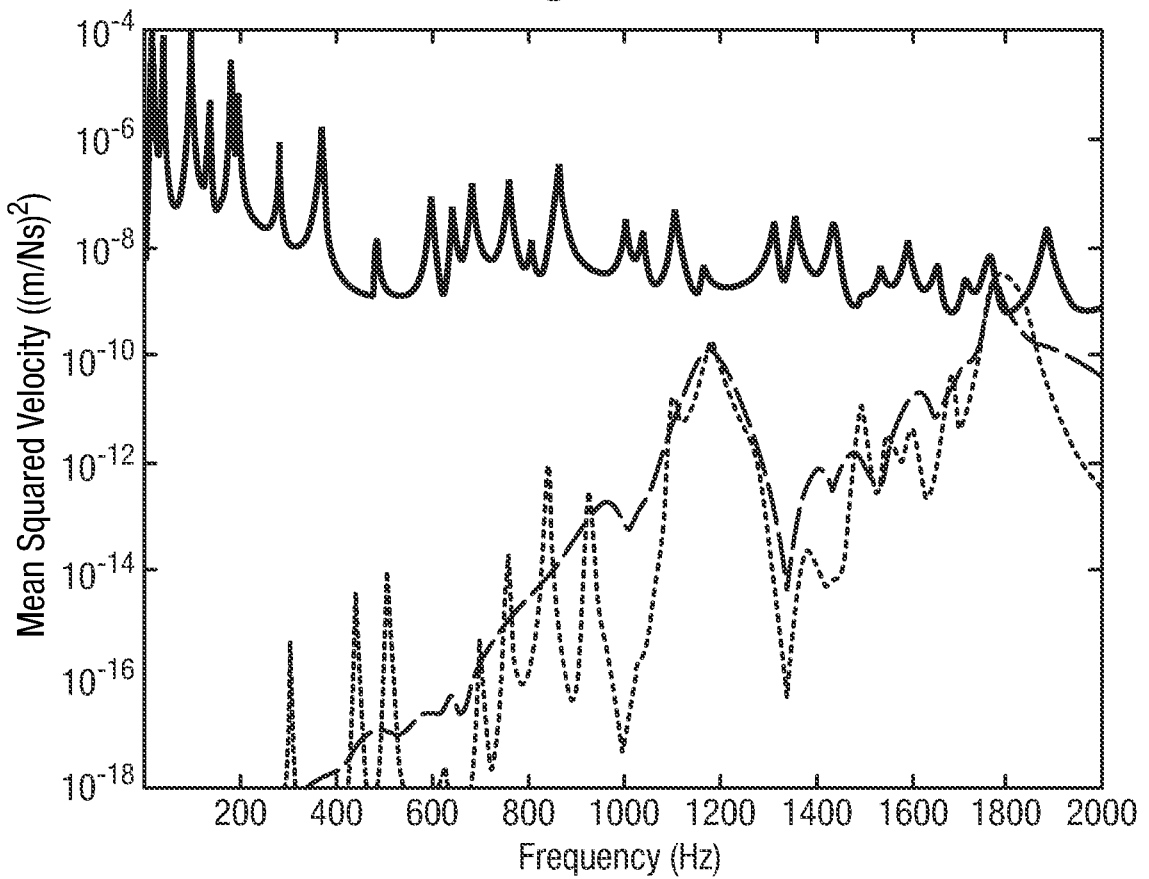

Fig. 7(a)

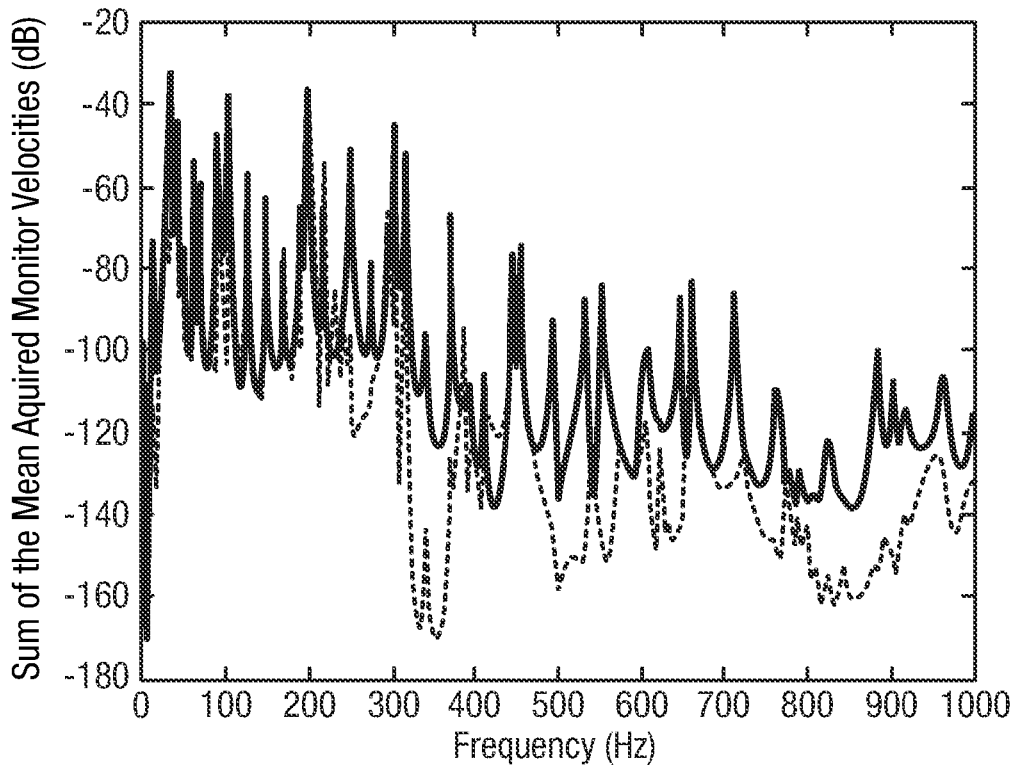

Fig. 7(b)

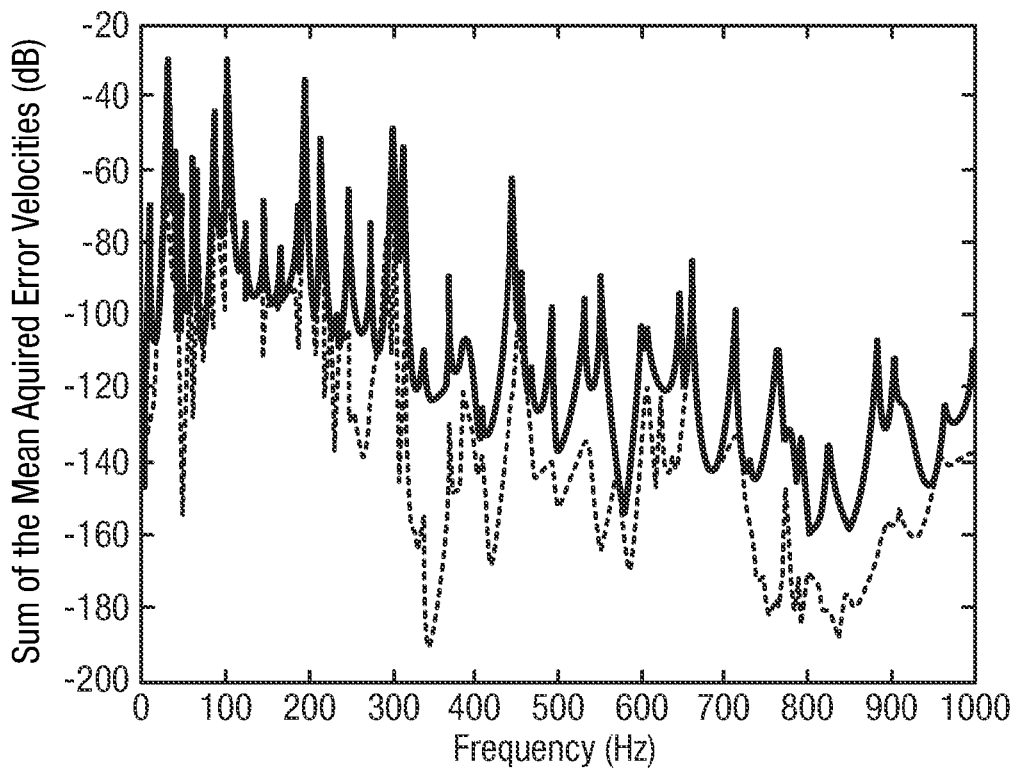

Fig. 8(a)

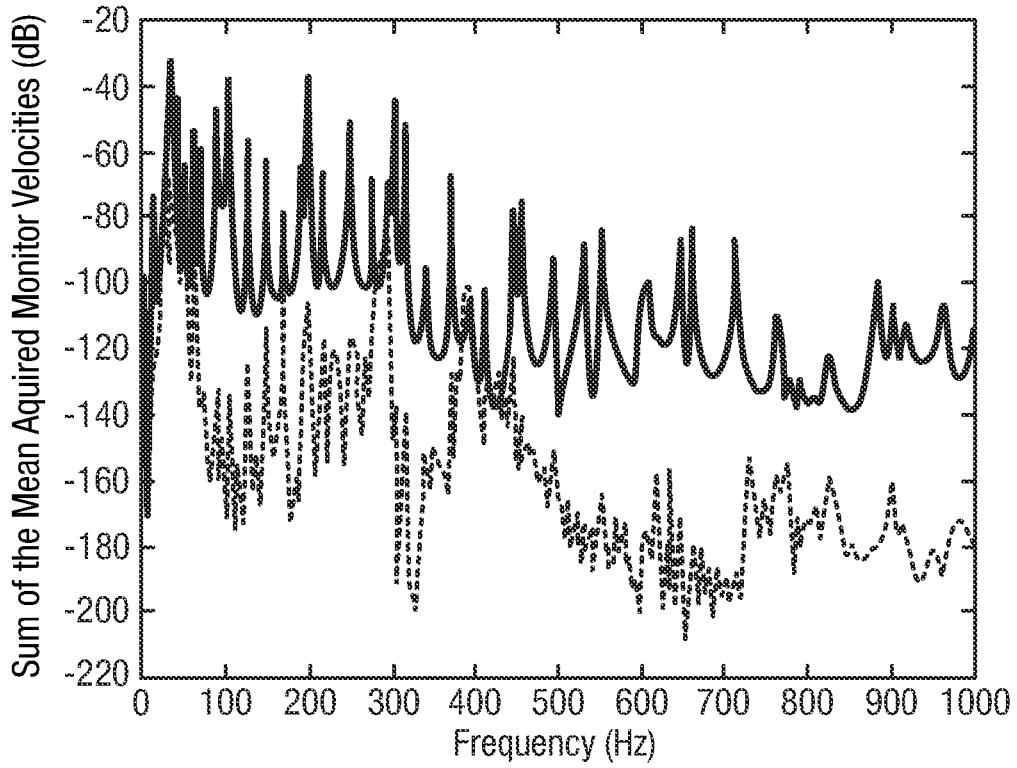

Fig. 8(b)

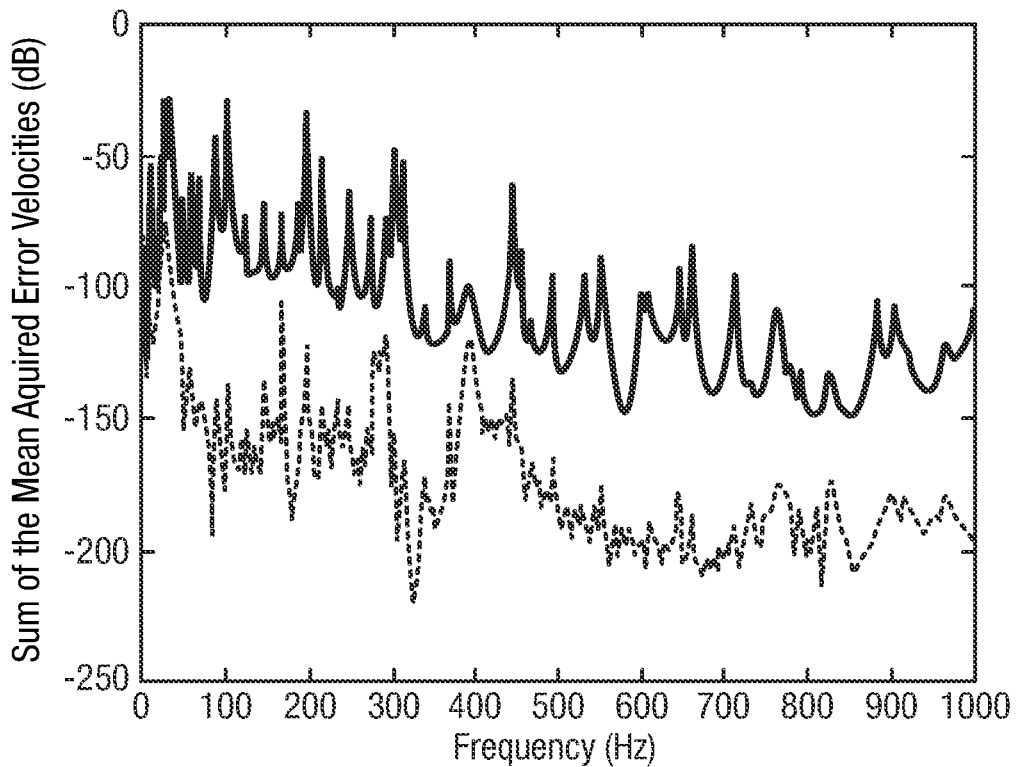

Fig. 9(a)

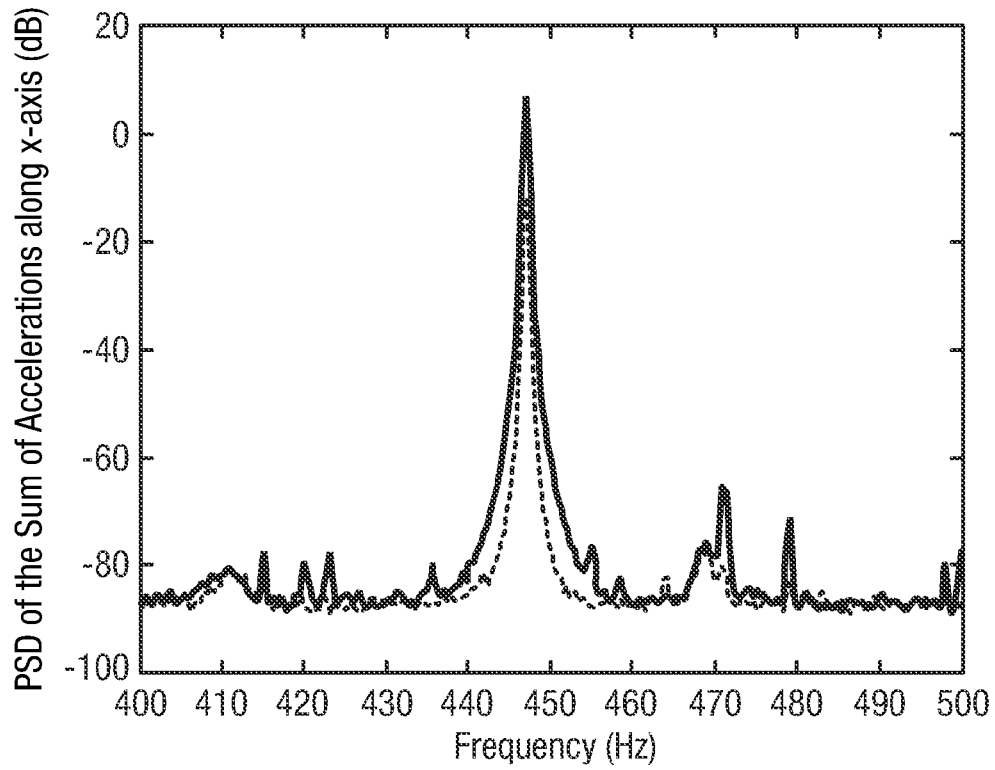

Fig. 9(b)

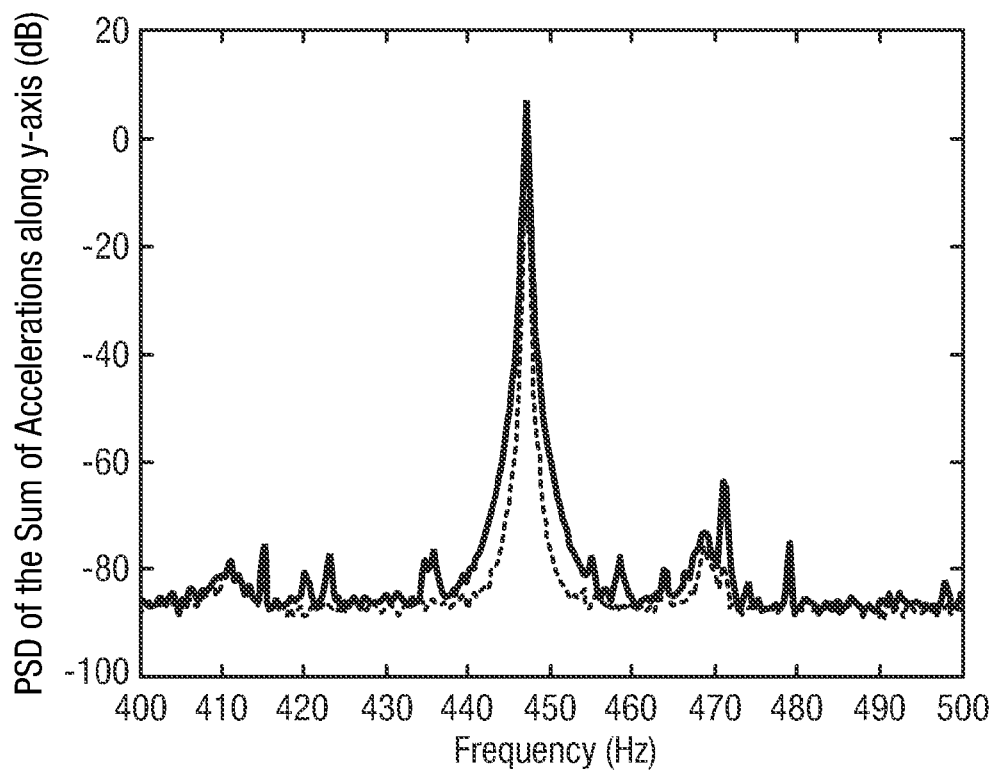
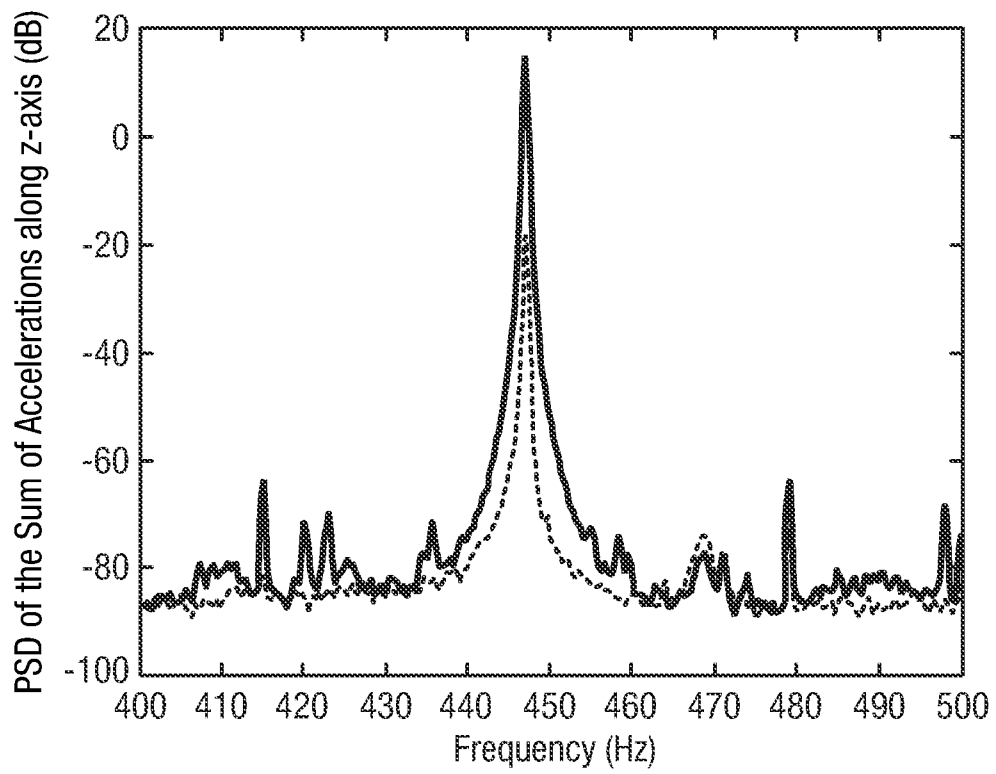

Fig. 9(c)



INTERNATIONAL SEARCH REPORT

International application No
PCT/GB2014/052002

A. CLASSIFICATION OF SUBJECT MATTER
 INV. F16F15/03 F16F7/10 F16F15/02 F16F15/00
 ADD.
 According to International Patent Classification (IPC) or to both national classification and IPC

B. FIELDS SEARCHED
 Minimum documentation searched (classification system followed by classification symbols)
 F16F

Documentation searched other than minimum documentation to the extent that such documents are included in the fields searched

Electronic data base consulted during the international search (name of data base and, where practicable, search terms used)
 EPO-Internal, WPI Data

C. DOCUMENTS CONSIDERED TO BE RELEVANT

Category*	Citation of document, with indication, where appropriate, of the relevant passages	Relevant to claim No.
X A	JP H07 113438 A (MURATA MACHINERY LTD) 2 May 1995 (1995-05-02) abstract; figures -----	1,6,7,9, 14,15 8,10-13
X A	JP S59 50243 A (NIPPON KOKAN KK) 23 March 1984 (1984-03-23) abstract; figures -----	1,5,7,9, 14,15 8,10-13
Y	US 1 819 665 A (WILTSE JEROME A) 18 August 1931 (1931-08-18) the whole document -----	1,4,6-15
Y A	US 5 883 447 A (CLAUSIN JACQUES [FR]) 16 March 1999 (1999-03-16) the whole document -----	1,4,6-15 3
	-/--	

Further documents are listed in the continuation of Box C.

See patent family annex.

* Special categories of cited documents :

<p>"A" document defining the general state of the art which is not considered to be of particular relevance</p> <p>"E" earlier application or patent but published on or after the international filing date</p> <p>"L" document which may throw doubts on priority claim(s) or which is cited to establish the publication date of another citation or other special reason (as specified)</p> <p>"O" document referring to an oral disclosure, use, exhibition or other means</p> <p>"P" document published prior to the international filing date but later than the priority date claimed</p>	<p>"T" later document published after the international filing date or priority date and not in conflict with the application but cited to understand the principle or theory underlying the invention</p> <p>"X" document of particular relevance; the claimed invention cannot be considered novel or cannot be considered to involve an inventive step when the document is taken alone</p> <p>"Y" document of particular relevance; the claimed invention cannot be considered to involve an inventive step when the document is combined with one or more other such documents, such combination being obvious to a person skilled in the art</p> <p>"&" document member of the same patent family</p>
---	---

Date of the actual completion of the international search 20 August 2014	Date of mailing of the international search report 29/08/2014
---	--

Name and mailing address of the ISA/ European Patent Office, P.B. 5818 Patentlaan 2 NL - 2280 HV Rijswijk Tel. (+31-70) 340-2040, Fax: (+31-70) 340-3016	Authorized officer Tsitsilonis, Lucas
--	--

INTERNATIONAL SEARCH REPORT

International application No
PCT/GB2014/052002

C(Continuation). DOCUMENTS CONSIDERED TO BE RELEVANT		
Category*	Citation of document, with indication, where appropriate, of the relevant passages	Relevant to claim No.
X	JP H04 281870 A (TOSHIBA CORP) 7 October 1992 (1992-10-07) the whole document -----	1-3,5, 7-15
X	DE 10 2007 015634 A1 (SCHAEFFLER KG [DE]) 2 October 2008 (2008-10-02) abstract; claims 1,6-10; figures -----	1-3,5,8, 9,14,15
X	JP H05 26291 A (SUGIYAMA YOSHIHIKO; KYOHARA MASAKO) 2 February 1993 (1993-02-02) abstract; figures -----	1,4,14, 15
X	JP 2008 265379 A (YANMAR CO LTD) 6 November 2008 (2008-11-06) abstract; figures -----	1,14,15
A	US 2009/023571 A1 (KUSUMOTO SHOJI [JP] ET AL) 22 January 2009 (2009-01-22) the whole document -----	1-3,6, 14,15
A	US 5 251 863 A (GOSSMAN WILLIAM [US] ET AL) 12 October 1993 (1993-10-12) abstract; figures -----	1,14,15
A	US 5 845 236 A (JOLLY MARK R [US] ET AL) 1 December 1998 (1998-12-01) the whole document -----	1,14,15
A	JP H05 172183 A (ANDO CONSTR) 9 July 1993 (1993-07-09) abstract; figures -----	1,14,15
A	EP 0 552 695 A1 (ALENIA AERITALIA & SELENIA [IT]) 28 July 1993 (1993-07-28) the whole document -----	1,14,15
A	JP 2009 091859 A (BRIDGESTONE CORP) 30 April 2009 (2009-04-30) abstract; figures -----	1,14,15
A	JP H05 18437 A (HITACHI PLANT ENG & CONSTR CO) 26 January 1993 (1993-01-26) abstract; figures -----	1,14,15
A	JP 2003 278830 A (MITSUBISHI HEAVY IND LTD) 2 October 2003 (2003-10-02) abstract; figures -----	1-3,14, 15
A	US 4 282 938 A (MINAMIDATE MAKOTO) 11 August 1981 (1981-08-11) figures 6,9 -----	1,14,15

INTERNATIONAL SEARCH REPORT

Information on patent family members

International application No

PCT/GB2014/052002

Patent document cited in search report		Publication date	Patent family member(s)	Publication date
JP H07113438	A	02-05-1995	NONE	
JP S5950243	A	23-03-1984	JP H037816 B2 JP S5950243 A	04-02-1991 23-03-1984
US 1819665	A	18-08-1931	NONE	
US 5883447	A	16-03-1999	DE 69603156 D1 DE 69603156 T2 EP 0807216 A1 FR 2730288 A1 JP H10513246 A US 5883447 A WO 9623986 A1	12-08-1999 27-01-2000 19-11-1997 09-08-1996 15-12-1998 16-03-1999 08-08-1996
JP H04281870	A	07-10-1992	NONE	
DE 102007015634	A1	02-10-2008	NONE	
JP H0526291	A	02-02-1993	JP 3226222 B2 JP H0526291 A	05-11-2001 02-02-1993
JP 2008265379	A	06-11-2008	JP 5225605 B2 JP 2008265379 A	03-07-2013 06-11-2008
US 2009023571	A1	22-01-2009	DE 102007040571 A1 JP 4569778 B2 JP 2008055368 A US 2009023571 A1	10-04-2008 27-10-2010 13-03-2008 22-01-2009
US 5251863	A	12-10-1993	AT 176720 T CA 2142012 A1 DE 69228430 D1 DE 69228430 T2 EP 0654132 A1 US 5251863 A WO 9404866 A1	15-02-1999 03-03-1994 25-03-1999 16-09-1999 24-05-1995 12-10-1993 03-03-1994
US 5845236	A	01-12-1998	CA 2269424 A1 EP 0932895 A1 US 5845236 A WO 9816916 A1	23-04-1998 04-08-1999 01-12-1998 23-04-1998
JP H05172183	A	09-07-1993	NONE	
EP 0552695	A1	28-07-1993	CA 2087669 A1 EP 0552695 A1 IT 1256769 B US 5361878 A	22-07-1993 28-07-1993 15-12-1995 08-11-1994
JP 2009091859	A	30-04-2009	JP 5102577 B2 JP 2009091859 A	19-12-2012 30-04-2009
JP H0518437	A	26-01-1993	NONE	
JP 2003278830	A	02-10-2003	NONE	
US 4282938	A	11-08-1981	JP S572473 B2	16-01-1982

INTERNATIONAL SEARCH REPORT

Information on patent family members

International application No

PCT/GB2014/052002

Patent document cited in search report	Publication date	Patent family member(s)	Publication date
		JP S54127080 A	02-10-1979
		US 4282938 A	11-08-1981
<hr/>			