

DISI - Via Sommarive 14 - 38123 Povo - Trento (Italy)
<http://www.disi.unitn.it>

Continual egocentric object recognition

Luca Erculiani, Fausto Giunchiglia, Andrea
Passerini

February 2020

Technical Report # DISI-20-003

24th European Conference on Artificial Intelligence,
2020

Continual egocentric object recognition

Luca Erculiani and Fausto Giunchiglia and Andrea Passerini¹²

Abstract. We are interested in the problem of continual object recognition in a setting which resembles that under which humans see and learn. This problem is of high relevance in all those applications where an agent must work collaboratively with a human in the same setting (e.g., personal assistance). The main innovative aspects of this setting with respect to the state-of-the-art are: it assumes an egocentric point-of-view bound to a single person, which implies a relatively low diversity of data and a cold start with no data; it requires to operate in an open world, where new objects can be encountered *at any time*; supervision is scarce and has to be solicited to the user, and completely *unsupervised recognition* of new objects should be possible. Note that this setting differs from the one addressed in the open world recognition literature, where supervised feedback is always requested to be able to incorporate new objects. We propose an incremental approach which is based on four main features: the use of time and space persistency (i.e., the appearance of objects changes relatively slowly), the use of similarity as the main driving principle for object recognition and novelty detection, the progressive introduction of new objects in a developmental fashion and the selective elicitation of user feedback in an online active learning fashion. Experimental results show the feasibility of open world, generic object recognition, the ability to recognize, memorize and re-identify new objects even in complete absence of user supervision, and the utility of persistency and incrementality in boosting performance.

1 Introduction

Over the last few years Deep Neural Networks led to massive improvements for the tasks of object detection and recognition in images [9, 22]. The main application scenario for this work was the use of large sets of photos, most of the time collected from the Web, to reliably identify objects from an increasingly large but static hierarchy of classes [25]. One of the key factors of the success of these approaches has been the availability of large datasets of (annotated) images and videos [5].

Our motivating scenario is quite different. We are interested in recognizing objects in a setting which resembles that under which humans see and perceive the world. This problem is of high relevance in all those applications where there is a wearable camera (e.g., in the glasses) which generates images or videos whose recognition can be used to support the user in her local needs (e.g., everyday life, working tasks). The main innovative characteristics in this setting are: (i) it assumes an egocentric setting [30], where the input is the point-of-view of a single person (i.e., the data has low diversity and high correlation); (ii) there is a continuous flow of input data, with new objects appearing all the time (i.e., we assume the agent operates in an open world); (iii) recognition should be able to go as deep as

instance-level re-identification (e.g. recognizing my own mug); (iv) supervision is scarce and should be solicited to the user when needed, also accounting for entirely autonomous identification and processing of new objects.

This scenario contrasts with the typical setting in which deep learning architectures shine. Incorporating novel classes is a notoriously hard problem for deep networks. The way in which these networks are trained drives them to learn models that implicitly follow the closed world assumption, and trying to dynamically expand their capabilities negatively affects previous knowledge (the so-called catastrophic forgetting [8]). While substantial progresses have been made in fields like continual lifelong learning [20] and few-shot learning [11], the state-of-the-art algorithms in this field are far from being able to match the capabilities of humans. We argue that a key factor for this gap is the way these algorithms are exposed to the data during training, with respect to what happens for humans and other animals. Humans experience the world via a continuous stream of highly correlated visual stimuli, initially focused on very few objects. This allows them to progressively acquire an understanding of the difference ways in which objects can appear, and on the similarities and differences between objects.

On these premises, the solution proposed in this paper is based on the following intuitions:

- Introduce persistency as a key element for instance-level labeling. By this we mean the fact that when we see an object as part of a video the object will change very slowly, allowing to identify *visual invariances* useful for subsequence recognition. This is thought to be one of the key aspects for early visual learning in children [6, 18].
- Use similarity as the main driving principle for object recognition and novelty detection. This is consistent with the recent trend in few-shot [11, 31] and open-world [1, 24]) learning, and we extend it here the autonomous recognition of new objects.
- Progressively introduce novel objects in a developmental fashion [3, 30], and provide supervision on-demand in an online active learning fashion.

The proposed algorithm, which we named FOLLOWER, performs online open-world object recognition over a continuous stream of videos of objects, taking an egocentric point-of-view bound to a specific user. Our experimental evaluation is promising, and highlights the importance of persistency, especially when dealing with instance-level recognition, the ability to identify and memorize novel objects even in complete absence of user supervision, and the role of developmental learning in boosting performance.

¹ University of Trento, Italy, email: *name.surname@unitn.it*

² Under review at ECAI 2020

2 Related Work

Our framework is related to the task of continual lifelong learning [20]. In continual lifelong learning the learner is presented as sequence of study-sessions, each focused on a novel class, and the goal of the learner is being able to incorporate new classes without forgetting previously learned ones. The main approaches to address the problem are constraining model updates to limit interference with previous knowledge [36, 35], and learning separate subsystems to handle short- and long-term memory [7]. While still aiming at continual learning, our framework is substantially different as there is no separate teaching session for each class, but rather a continuous stream of objects with on-demand supervision, the focus is on recognizing individual objects, and we assume a regime of scarce labelled data.

Few-shot learning is the problem of learning a task when very few data is available for training. Existing research either focus on combining metric and class prototype learning [11, 32], or frame the problem as meta-learning [26, 15]. As for continual lifelong learning, these approaches typically assume a set of class-specific teaching sessions. Our solution shares the idea of using similarity-based solutions to cope with data scarcity, but frames it in an online, active learning setting where new objects can appear at all times, in a fully open-world scenario.

Getting rid of the closed-world assumption is a recent research trend in the machine learning community. The problem was first framed in terms of *open set* learning, i.e. learn to identify examples of unknown classes [27, 2]. More recently, *open world* learning has been introduced, where the learner should both identify examples of unknown classes, and be able to add them in the future as a novel class, if new external supervision is made available. As happens for most few-shot learning strategies, existing approaches for open world learning are similarity-based [1, 24]. Still, these works assume that novel classes are incorporated via class-specific training sessions, and their main objective is minimizing the effort required to update their internal representations. Our solution adapts this similarity-based principle to deal with user supervision in an online active learning fashion, and to work in an instance-level object recognition scenario.

The task of discriminating objects at an instance level is usually referred to as *re-identification* in the computer vision community. The most prominent applications in this field are related to the identification of humans [34], with some works focusing on vehicle re-identification [28]. Most of these approaches are again similarity-based, with embeddings of images or videos learned using Siamese Neural Networks [11]. The main drawbacks of these approaches is the fact that they were specifically developed to deal with single categories of objects (humans or vehicles), while we aim at re-identification of generic objects. Furthermore, re-identification assumes that the object to be re-identified is already present in memory, while we focus on an open-world setting where new objects are continuously presented and need to be identified, stored and re-identified at subsequent encounters.

What we share with the re-identification literature is the idea of using videos of objects for identification/recognition, rather than for e.g. activity recognition or tracking. This allows to exploit space and time persistency to build a better picture of the characteristics of an object. Indeed, recent works [16, 12] have shown how unsupervised pre-training with videos allows to learn useful representations for image classification tasks, and how few videos of a given class of objects are sufficient to train a detector for that class [21].

These works suggest that inside a video stream there is an incredible amount of information, that can be used to model the recorded subjects. We aim to leverage on this information to build an effective few-shot object recognition algorithm from videos.

In the robotics field, a number of works have focused on studying approaches for human-guided interactive learning [33, 10, 29, 17, 19]. In this setting a machine is trained to recognize objects that are manipulated by a human [33, 10], or directly by the robot [17], asking supervision to the user if the object is considered unknown. While sharing similarities with our setting, these approaches are focused on recognizing what is known and rejecting what is unknown, and always require human intervention in order to expand of the pool of known objects. In contrast, we aim at building systems that can autonomously discriminate the unknown and integrate it with the previous knowledge, expanding the pool of recognized entities even without human intervention.

3 The Recognition Framework

We first describe the setting in which the agent is expected to operate, and then present a learning algorithm which we consider appropriate for the setting.

3.1 The Setting

As explained in the introduction, we focus on open-world, incremental instance-level object recognition, with an egocentric view bound to a specific user. Note that we assume maximal granularity, meaning that each object has its own class, and the goal of the algorithm is to cluster input data rather than assigning a label to each sample (see Section 5 for a hint on how to generalize to mixed instance-level and class-level recognition). The information is made available to the learning agent via a continuous stream of data. Each sample in this stream is a short video, focused on a certain object. The goal of the agent is, for each new video, to determine if it contains an object it has already seen, or if it shows an object it sees for the first time. After the first encounter, the agent should add the new object to the pool of objects it knows, so as to recognize it in the future. The agent can query the user in order to gather supervision on instances it considers uncertain and prevent taking wrong decisions, in an online active learning fashion.

3.2 The Algorithm

The pseudocode of the algorithm is shown in Algorithm 1. It takes as input a stream of video sequences S and a single parameter $\alpha \in [0, 1]$ that represents the amount of effort the user is expected to provide on average, in terms of number of queries. The algorithm consists of an iterative routine that receives in input a new video s at each iteration. The new video is transformed in a fixed size representation $r_s \in R^n$, by generating embeddings for each frame using ResNet152 [9], and computing the mean of the embeddings of the frames. We tested more advanced aggregation methods, such as LSTMs, but we found these underperforming, likely because these architectures require an offline training phase with a lot of training data, a rather different setting from the one we are facing.

The resulting representation is compared with a collection of representations of past videos, that the algorithm has stored in its memory. The algorithm then decides if there exists a representation in memory that contains the very same object, at instance level. It starts by computing the distance δ between the new representation and its

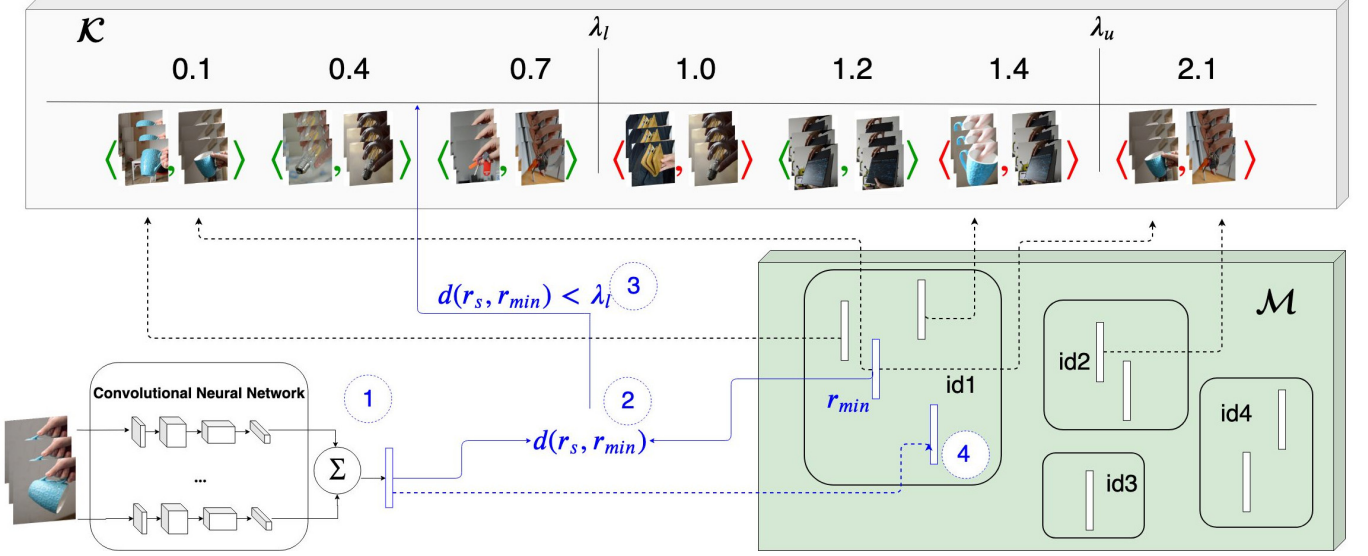

Figure 1: Graphical representation showing an iteration of our algorithm. In black the state of the algorithm at the end of the previous iteration. In green and red the tuples of same and different objects inside \mathcal{K} . In blue the operations that occur at the current iteration. The new video s is converted in an embedding r_s (1) and its nearest neighbor r_{min} is identified (2). Given that their distance is lower than λ_l (3), r_s is added to the memory \mathcal{M} with the same identifier of r_{min} (4), and the iteration finishes. No user feedback is required in this iteration.

Algorithm 1 Open world egocentric object recognition

Input : a stream of videos S

Input : a real value $\alpha \in [0, 1]$

- 1: **procedure** FOLLOWER(S, α)
 - 2: $\mathcal{M} \leftarrow \emptyset; \mathcal{K} \leftarrow \emptyset$
 - 3: **while** $s \leftarrow \text{next}(S)$ **do**
 - 4: $r_s \leftarrow \text{embedVideo}(s)$
 - 5: $r_{min}, l_{min} \leftarrow \text{getNearestNeighbour}(r_s, \mathcal{M})$
 - 6: $\delta \leftarrow d(r_s, r_{min})$
 - 7: $\lambda_l, \lambda_u \leftarrow \text{getDecisionThresholds}(\mathcal{K}, \alpha)$
 - 8: **if** $\delta < \lambda_l$ **then**
 - 9: $l_s \leftarrow l_{min}$
 - 10: **else if** $\delta > \lambda_u$ **then**
 - 11: $l_s \leftarrow \text{newId}()$
 - 12: **else**
 - 13: $y \leftarrow \text{askUserSupervision}(r_s, r_{min})$
 - 14: **if** y **then**
 - 15: $l_s \leftarrow l_{min}$
 - 16: **else**
 - 17: $l_s \leftarrow \text{newId}()$
 - 18: $\mathcal{K} \leftarrow \mathcal{K} \cup \{(\delta, y)\}$
 - 19: $\mathcal{M} \leftarrow \mathcal{M} \cup \{(r_s, l_s)\}$
-

nearest neighbor r_{min} (in memory). Based on this distance it needs to decide among three possible options: 1) the object is the same as the one retrieved from memory; 2) the object is a new one; 3) there is not enough evidence to make a decision, and the user feedback is needed. The choice among the three options is made by comparing the distance δ with a pair of thresholds λ_l, λ_u , computed using a procedure described later on. If $\delta < \lambda_l$, the object is recognized as already seen (option 1), and it is assigned the same identifier l_{min} of its nearest neighbour. If $\delta > \lambda_u$ the object is considered a new one (option 2) and it is assigned a brand new identifier. Otherwise, a user feedback is requested (option 3). In this latter case, the user is

asked whether r_s and r_{min} are the same objects, and the identifier of the object is updated according to the user feedback. Finally the new object-label pair is added to the memory \mathcal{M} . If the algorithm decided to request the user supervision, the answer to its query is stored in another memory \mathcal{K} , together with the distance δ . Then the whole process is repeated with a new video.

As described above, the whole decision process depends on the values of the two thresholds λ_l and λ_u . These thresholds are estimated at each iteration by using the information provided by the user, in the form of the collection $\mathcal{K} = \{(\delta_i, y_i) \mid 1 < i < |\mathcal{K}|\}$ of distances between pairs of objects $\delta_i = d(r_i, r'_i)$, coupled with a boolean value y_i , that represents the supervision from the user (i.e., $y_i = \top$ if r_i and r'_i are the same object, $y_i = \perp$ otherwise). As usual when using distance-based classification techniques, the underlying assumption is that the embeddings of various instances of the same object are closer together than those of different objects. Based on this assumption, `getDecisionThresholds` sets the two thresholds so as to maximize the probability that if δ is inside these boundaries, the algorithm would take a wrong decision on the corresponding object, given the information currently stored in memory. This is achieved by solving the following optimization problem:

$$\begin{aligned}
 & \underset{\lambda_l, \lambda_u}{\text{argmax}} && H(\mathcal{Y}_{\lambda_l}^{\lambda_u}) - H(\mathcal{Y}^{\lambda_l}) - H(\mathcal{Y}_{\lambda_u}) && (1) \\
 & \text{subject to:} && \mathcal{Y}_{\lambda_l}^{\lambda_u} = \{y \mid \langle y, \delta \rangle \in \mathcal{K} \wedge \lambda_l \leq \delta \leq \lambda_u\} \\
 & && \mathcal{Y}^{\lambda_l} = \{y \mid \langle y, \delta \rangle \in \mathcal{K} \wedge \delta \leq \lambda_l\} \\
 & && \mathcal{Y}_{\lambda_u} = \{y \mid \langle y, \delta \rangle \in \mathcal{K} \wedge \lambda_u \leq \delta\} \\
 & && \sum_{i=1}^{|\mathcal{K}|} \mathbb{1}(\lambda_l \leq \delta_i \leq \lambda_u) = \lceil \alpha |\mathcal{K}| \rceil && (2)
 \end{aligned}$$

Here $\mathcal{Y}_{\lambda_l}^{\lambda_u}$ is the set of user answers related to objects with a distance within the two thresholds, while \mathcal{Y}^{λ_l} and \mathcal{Y}_{λ_u} are the sets related to objects below λ_l and above λ_u respectively. The function H returns

the entropy of a given set. Eq. 2 imposes the constraint that the user is queried with probability α , where the probability is estimated using the currently available feedback. The objective function is chosen in order to set the two thresholds in the area where the algorithm is maximally confused, adjusting the size of the area to the effort the user is willing to provide. During training, the algorithm will receive supervision only for those examples where $\lambda_l \leq \delta_i \leq \lambda_u$. Thus only these elements will be added to the supervision memory \mathcal{K} , increasing the fraction of elements in \mathcal{K} having a distance between the two thresholds. This, combined to the fact that α remains constant during training, will eventually lead to selecting two closer and closer values for λ_l, λ_u , reducing the size of the area of confusion and thus the probability to request supervision. An alternative approach could be leaving the algorithm the freedom to select the optimal size for the confusion area (leaving α as an upper limit). We tested this approach, but we found that this led to instability during training, due to poor estimates of the correct size of the confusion area.

Another advantage of formulating the constraints as in Eq. (2) is the ability to solve the maximization problem efficiently, provided that the content of \mathcal{K} is stored inside a list that is kept sorted with respect to δ_i . We refer to this list as $\text{sorted}(\mathcal{K})$. Then the optimal solution is associated to one of the contiguous sub-lists of $\text{sorted}(\mathcal{K})$ of length $\lceil \alpha|\mathcal{K}| \rceil$. Let $\langle \delta_j, e_j \rangle$ and $\langle \delta_k, e_k \rangle$ be the first and last element of a sub-list S , where j, k refer to the positions of the elements in the full list $\text{sorted}(\mathcal{K})$, so that $k = j + \lceil \alpha|\mathcal{K}| \rceil$. Setting $\lambda_l^S = \delta_j$ and $\lambda_u^S = \delta_k$ guarantees that the constraint in Eq. (2) is satisfied. Our algorithm evaluates the objective (1) for each of the contiguous sub-lists (there are at most $|\mathcal{K}|$ of them) and returns the values $\lambda_l = \lambda_l^{S^*}, \lambda_u = \lambda_u^{S^*}$ corresponding to the sub-list S^* for which the objective is maximized.

For evaluation purposes as well as to allow the algorithm to work in absence of user supervision, it is useful to have a modality where asking the user is not an option, and the algorithm can only decide between recognizing the object as already seen or considering it a new object. This can be done defining a single “recognition” threshold λ_r , such that if δ is lower than the threshold the object is recognized as the same as its nearest neighbor, otherwise it is considered a new object. The threshold can be set in order to maximize the number of correct predictions given the available supervision \mathcal{K} , by solving the following optimization problem:

$$\lambda_r = \underset{\lambda}{\operatorname{argmax}} \sum_{i=1}^{|\mathcal{K}|} \mathbb{1}((\delta_i < \lambda) \oplus \neg y_i) \quad (3)$$

where $\mathbb{1}$ is the indicator function mapping true to 1 and false to 0, and \oplus is the exclusive OR. This problem too can be solved in time linear in the size of \mathcal{K} , by just testing all thresholds $\lambda^i = \frac{\delta_i + \delta_{i+1}}{2}$ for $i \in [0, |\mathcal{K}|]$ (where $\delta_0 = \delta_1 - \epsilon$ and $\delta_{|\mathcal{K}|+1} = \delta_{|\mathcal{K}|} + \epsilon$ for an arbitrary small ϵ).

4 Evaluation

The framework described in Section 3 differs in many aspects from the ones of mainstream classification algorithms. For this reason, commonly used benchmarks meant for classification, even those employed for continuous lifelong learning, aren’t suited to evaluate our approach. The ideal dataset should contain a collection of videos, each focused a single instance of an object, with the same object appearing in multiple videos over different backgrounds, somehow emulating the first stages of developmental learning under an egocentric point-of-view [30]. The egocentric perspective was selected

because it is the most natural setting for this task. It mimics the behavior of a user who focuses on an object she is interested in, rotates and deforms different perspectives.

As far as we know only two public datasets satisfy these requirements [23, 14]. The larger of the two, called CoRe50 [14] contains a total of 50 objects, each recorded 11 different times. Given that our goal is to measure the ability to deal with the unknown in an incremental scenario, we need to prioritize the number of different objects over the number of recorded sequences. Thus, we collected a new dataset of videos of objects commonly found in office/home spaces. The dataset contains 500 short videos of 100 different objects, 5 videos per object, recorded with different backgrounds, and it will be freely available³, as well as the python code used to run the experiments⁴. The main findings in this paper are however confirmed when evaluating our algorithm on the CoRe50 dataset.

4.1 The Role of Persistency

Our first experiment is aimed at investigating how exploiting persistency in space-time affects the recognition performance of our model. We compare our algorithm with an alternative model that does not make use of this feature. Without persistency, each frame of a sequence should be classified independently of the others, as if they were a collection of pictures. We performed these tests on a closed-world re-identification setting, similar to the one used in person re-identification [13, 34]. The aim of these tests is to evaluate the role of persistency independently of the other aspects of our framework, like open-world recognition and online active learning.

For each object in our dataset, we sampled one video for the training set and one for the test set. For each test sample, we then computed its nearest neighbor in the training set, where samples are videos when using persistency, and individual frames otherwise. Figure 2(left) reports the fraction of videos (or frames) that have as nearest neighbor a sample of the same object (i.e., we report the Cumulative Matching Characteristic used in re-identification, with a number of positions $k = 1$), averaged over 100 folds, for an increasing number of objects to re-identify. The advantage of using persistency is apparent, and while increasing the number of objects clearly decreases the performance of both alternatives, the gap is substantially preserved.

4.2 Instance-level Recognition

The network we use for embedding frames (ResNet152) was originally trained to classify objects of 1000 different classes of ImageNet, a database that follows the same structure of the WordNet lexical database. Even if the original training set covered a broad spectrum of the objects commonly found in tasks recognition (including some in our own dataset), ResNet was trained with class-level supervision, a way that explicitly pushes the network towards suppressing intra-class variance.

In order to assess the performance of our algorithm at instance-level object recognition, we performed a second series of re-identification experiments focused on the “coffee mug” synset. Note that the synset appears as a leaf in the tree of ImageNet, i.e., the network we use for the embedding is not trained to distinguish between different mugs, but to consider them as a single category. We recorder a small collection of videos of nine different coffee mugs (shown in the middle of Figure 2). Figure 2(right) presents the re-identification

³ early release: <https://figshare.com/s/c278f7ab4c49d10b6c00>

⁴ The code will be released upon acceptance

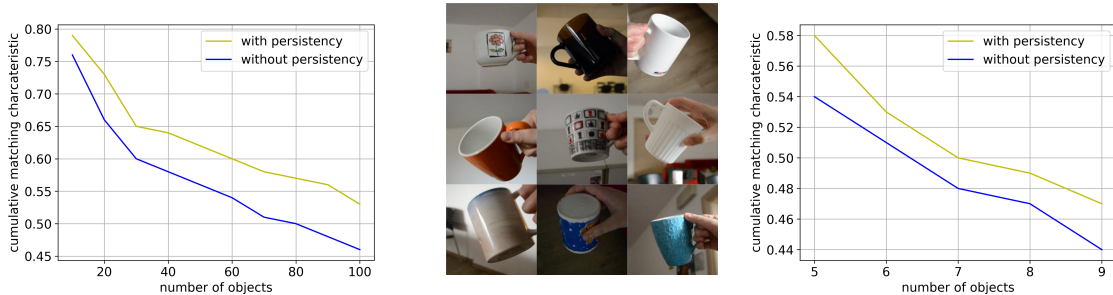

Figure 2: Re-identification results on generic objects (left) and on the coffee mugs (right) depicted in the middle.

results. As expected, performance are lower than the ones for generic objects, but the persistency model still obtains consistently better results than the frame-based one.

4.3 Open World Experiments

The next series of experiment aims at evaluating the performance of our algorithm in the setting described in Section 3.1. One of the key elements that distinguish our setting from a standard object recognition one is the fact that data arrive as a continuous stream, as typical of online learning settings, and the order in which data are presented to the algorithm can have an impact on the quality of learning [3]. In infants, the ratio at which novel objects appear is considered crucial for the development of their recognition capabilities [30, 4]. In order to investigate how this can affect our recognition algorithm, we considered two different policies for introducing novel objects. The first one, named `random`, presents videos in a random order. The second, that we named `devel` (short for developmental), at each iteration picks the video of a randomly chosen unseen object with probability 0.3, and randomly selects the video of an already seen object otherwise. We chose the probability 0.3 to evenly spread the encounter of new objects. Lowering the probability would result in showing all the videos of already seen objects before introducing a new one. Raising the probability would eventually result in showing all the unseen objects before showing a video of an already seen object, resulting in a behavior similar to the one obtained showing the sequences in random order (or even more pronounced). While being less intuitive, the `devel` setting is less artificial than the `random` setting, especially when the number of objects increases. Assuming that the dataset contains each object in the world, a `random` setting would imply that the user sees the majority of objects once, before interacting with an already seen object. That is not how a human interacts with the environment and learns. In this sense, the `devel` setting is clearly a better approximation of the behavior of a human.

For each of the two policies, we compared our recognition algorithm, FOLLOWER (see Algorithm 1) with a fully supervised version of the algorithm (which we refer to as FULLOWER), where user feedback is requested at each iteration.

The dataset was divided in three subsets. First, 10 objects were randomly selected, and all their sequences (50 in total) were used to perform unsupervised evaluation after the online training phase. For each of the remaining 90 objects, four videos were used for the interaction with the algorithm, while the fifth was kept in a separate set for online evaluation in the training phase. The procedure was repeated 2000 times with different permutations of the data and results were averaged.

4.3.1 Supervised phase evaluation

As FOLLOWER needs as input the expected user effort α , we tuned it so as to ask the minimum supervision required to have similar performance as FULLOWER. For the `random` setting, this was achieved with $\alpha = 0.92$, while in the `devel` setting, $\alpha = 0.35$ was sufficient. For the first 10 iterations FOLLOWER was forced to always ask for supervision, in order to bootstrap the estimation of its internal thresholds.

Figure 3 shows the results of our experiments in terms of user effort and recognition quality for an increasing number of objects presented to the algorithms, for the `random` (top row) and the `devel` (bottom row) setting respectively. The left column shows the average fraction of objects never shown to the algorithm up to that iteration included (green curve). The plot also shows the number of queries to the user for FOLLOWER (blue curve) and FULLOWER (constantly one, red curve); these can be interpreted as the probability to request supervision at each iteration. In the `random` setting, in the first iterations the vast majority of the videos contains brand new objects, while in the last iterations the probability of encountering something new is close to zero. The `devel` setting spreads the encounter of objects evenly, except for the last iterations when almost all objects have already been seen. This latter setting is highly beneficial in terms of user effort, as the amount of supervision that FOLLOWER requests to match the performances of FULLOWER is far less than the one it needs in the random case, in agreement with what believed about infant learning [4].

The middle column in Figure 3 shows the “instantaneous” accuracy in classifying the next object (as brand new or as one already seen). This can be computed as:

$$\mathbb{1} \left(\begin{array}{c} \delta(r_s, r_{min}) \leq \lambda_r \wedge \text{same}(r_s, r_{min}) \\ \vee \\ \delta(r_s, r_{min}) > \lambda_r \wedge \nexists r'_s \in \mathcal{M} : \text{same}(r_s, r'_s) \end{array} \right) \quad (4)$$

where λ_r is the recognition threshold in eq. 3 (asking to the user is not an option here), \mathcal{M} is the memory of the algorithm (at each training iteration), r_{min} is the nearest neighbor in \mathcal{M} , and `same` is true if r_s and r_{min} are representations of the same object. For both settings, the drop in performance follows the shape of the probability of encountering new objects (that is, it decreases as the number of objects to recognize increase, like in the re-identification experiments shown in Fig. 2). By design (i.e., choice of the alpha values) the performance of the FOLLOWERS never fall much below the ones of the FULLOWERS. In both settings the performance increase towards the end, due to the fact that the algorithms are exposed mainly to objects they have already seen.

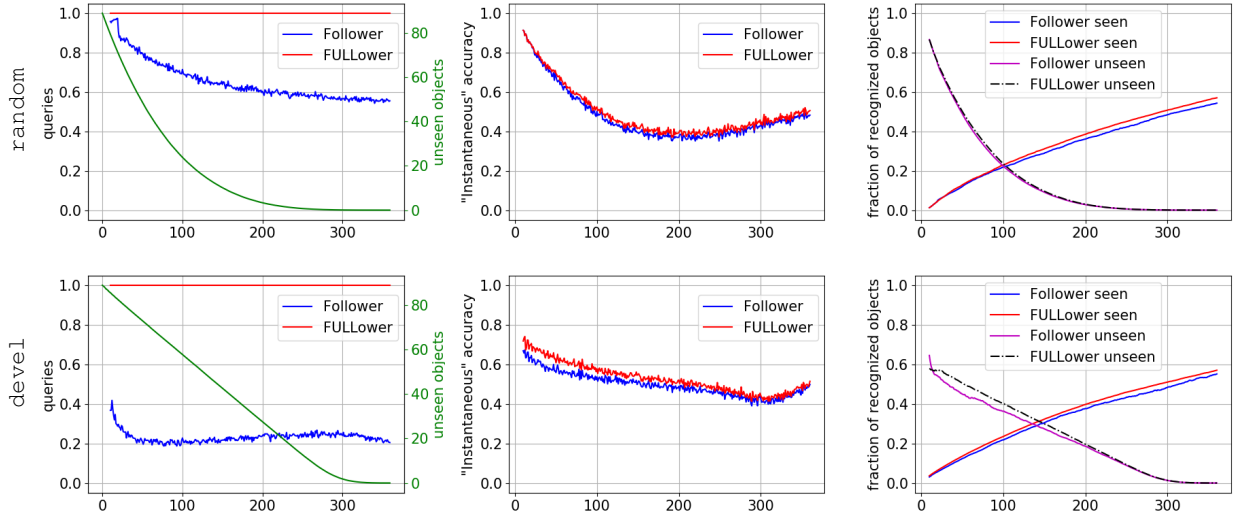

Figure 3: Open world recognition results for increasing number of iterations.

We also evaluated the performance of the algorithms on a separate *in-training* evaluation set, as customary in online learning settings. The right column in Figure 3 shows the fraction of correctly recognized objects (in red for FULLOWER, in blue for FOLLOWER):

$$\frac{1}{|S_{T_e}|} \sum_{s \in S_{T_e}} \mathbb{1}(\delta(r_s, r_{min}) \leq \lambda_r \wedge \text{same}(r_s, r_{min}))$$

and the fraction of examples correctly identified as unseen objects (in black for FULLOWER, in purple for FOLLOWER):

$$\frac{1}{|S_{T_e}|} \sum_{s \in S_{T_e}} \mathbb{1}(\delta(r_s, r_{min}) > \lambda_r \wedge \nexists r'_s \in \mathcal{M} : \text{same}(r_s, r'_s))$$

over the 90 hold-out videos S_{T_e} (one per object). In the *random* setting, due to the fact that in the first iterations the overwhelming majority of the encountered object were never seen before, the two algorithms are strongly biased towards marking every object as unseen. For this reason the green and purple curves are overlapping. Thanks to the large amount of supervision, the recognition performances over the already seen objects of FOLLOWER never falls too much below the one of FULLOWER.

In in *devel* scenario the algorithms are exposed to both new and unseen object right from the beginning. As FOLLOWER requests supervision only for ambiguous cases (i.e., nearest-neighbor distance neither low nor high enough), it is more biased towards predicting objects as seen with respect to FULLOWER. This, coupled with the fact that in this setting FOLLOWER requests supervision less than 30% of the times, results in a slightly lower performance in recognizing unseen objects with respect to FULLOWER. As the number of iterations increase, the performance gap shrinks. For the same reason FOLLOWER is able to closely match the performances of FULLOWER in in recognizing already seen objects.

The same trends were found when repeating these experiments over the CoRe50 dataset [14]. Figure 4 presents the results obtained over the *random* and *devel* setting, obtained using a value of α of 0.84 and 0.6 respectively. These two values were selected in order to minimize the amount of supervision in the two setting while keeping the performances at a level comparable with FULLOWER.

The results are in line with the ones obtained over our dataset. A *devel* setting still requires less effort from the user to enable FOL-

LOWER to match the performances of FULLOWER. Due to the fact that CoRe50 contains many sequences but fewer different objects (compared to our dataset), in the 90% of the iterations the models receive a sequence containing an already seen object. For this reason the FOLLOWER models make less queries on average for each iteration in the experiments involving this dataset.

The different number of sequences per object in the CoRe50 dataset, with respect to our dataset, led to have a distribution of unseen objects (the green curves in the first row of graphs) that is quite similar between *random* and *devel*. In both settings almost all the objects are shown to the models in the first 200 iterations. This is due to our choice to keep the parameters of the *devel* setting, i.e. the probability of encountering a new object, at the same value of the ones used in the experiments showed in the main paper. As a result, the graphs of the instantaneous accuracies and the recognition performances of seen and unseen objects, comparing the two settings, have a similar shape.

4.3.2 Unsupervised phase evaluation

The last series of tests are aimed at measuring the ability of the model to autonomously recognize and discriminate new objects. These tests are performed *after* the interactive training session with the user. The model is presented with all the 50 sequences of the 10 objects that were kept separate and never shown. The role of the model is to classify and store them as in the interactive phase, but without resorting on the supervision of the user. As for the training phase, we tested the performance of our algorithm by showing these 50 sequences both with a *random* and a *devel* policy⁵.

In this phase we computed the overall accuracy of the model, averaging the instantaneous accuracy (eq. 4) over all 50 decisions, one for each sequence. We refer to this metric as the Averaged Instantaneous Accuracy (AIA). As in this phase no supervision is provided by the user, this evaluation can be seen as a sort of incremental clustering. At each iteration the model observes a new sequence and decides whether to consider the object in it as the same as one seen

⁵ Given the low number of different objects, we decided not to compute the unsupervised evaluation on the CoRe50 dataset, in order to avoid to further reduce the number of objects in supervised evaluation

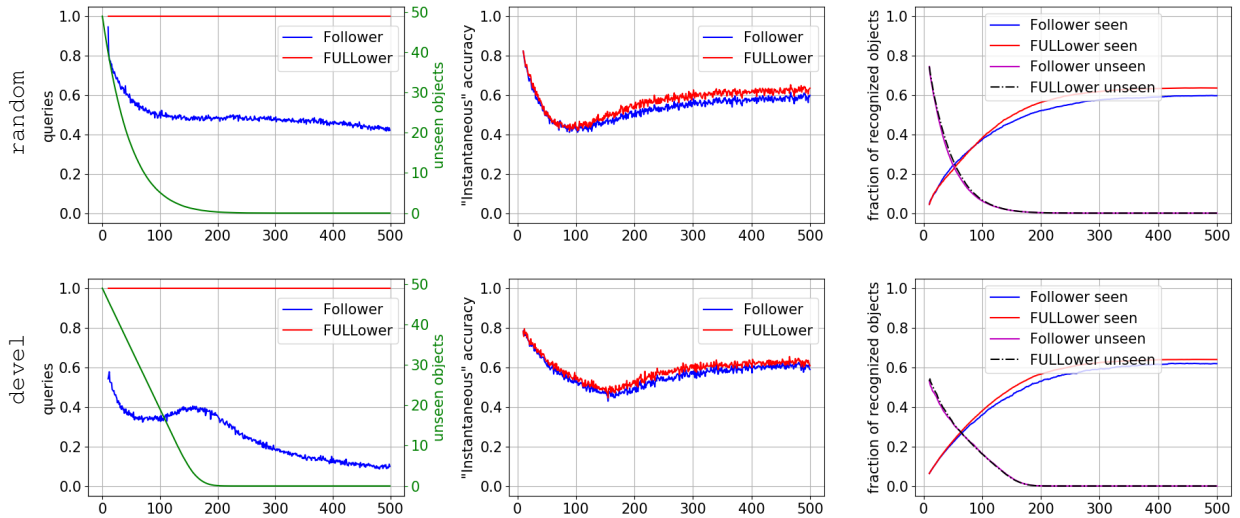

Figure 4: Open world recognition results on the CoRe50 dataset for increasing number of iterations.

previously (linking it to its nearest-neighbor in memory), or to add it as a novel object. Let’s consider a graph with sequences as nodes and an edge between each pair of nodes predicted as representing the same object. The connected components of this graph can be seen as clusters, each representing a (presumably) distinct object. We extracted these clusters for the 50 evaluation sequences and we computed two widely used clustering metrics, the Adjusted Mutual Information score (AMI) and Adjusted Rand Index score (ARI).

Table 1(top) shows the results obtained when presenting evaluation sequences using a `random` policy. The table shows the metrics described above, computed over FOLLOWER trained using a `random` (left) or a `devel` (right) policy. In order to compare the two training policies over the same number of examples, we tried different values of α so as to end up with an approximately equal number of training examples ($|\mathcal{K}|$ in the table), for a decreasing number of training examples. It is easy to see that when trained with the `random` policy, the performance of FOLLOWER are seriously affected by a decrease in the number of training instances. On the other hand, a `devel` policy during training enables the model to retain similar levels of accuracy even for substantially reduced amount of user feedback. While the clustering performance are more affected by the reduced level of supervision, this effect is much less pronounced when using a `devel` policy during training with respect to a `random` one.

Table 1(bottom) shows the results obtained when presenting evaluation sequences using a `devel` policy. The trends seen with the `random` evaluation policy are basically preserved here, with a `devel` policy at training time leading to better results than a `random` one. Comparing the two tables, it is apparent that FOLLOWER achieves massive improvements in recognition accuracy when evaluated with sequences in a `devel` rather than `random` order, with up to 100% increase in AIA. Clustering performance are also substantially better in most cases, especially when the models is trained with a `devel` policy. Note that the decrease in clustering performance when reducing the number of training examples is more pronounced here with respect to the top part of the table. This is due to the fact that a `devel` evaluation policy allows the method to substantially increase its ability to recognize already seen objects, at the cost of a relative decrease in ability to identify the unknown. In

absolute terms, however, also in terms of clustering the best results are achieved when FOLLOWER is both trained and evaluated with a `devel` policy.

Table 1: Test phase evaluation results. Top results refer to a `random` evaluation policy, bottom ones to a `devel` one. Results are computed over FOLLOWER trained using a `random` (left) or a `devel` (right) policy.

		random				devel			
		$ \mathcal{K} $	AIA	ARI	AMI	$ \mathcal{K} $	AIA	ARI	AMI
random		285	0.47	0.45	0.38	289	0.46	0.44	0.38
		237	0.45	0.43	0.37	240	0.46	0.42	0.36
		210	0.43	0.39	0.34	203	0.45	0.42	0.36
		177	0.4	0.35	0.31	152	0.45	0.41	0.35
		81	0.32	0.21	0.2	84	0.45	0.4	0.38
		36	0.33	0.22	0.21	37	0.45	0.35	0.37
devel		285	0.73	0.56	0.5	289	0.73	0.6	0.54
		237	0.73	0.49	0.45	244	0.73	0.56	0.52
		210	0.72	0.44	0.4	203	0.73	0.55	0.5
		177	0.71	0.37	0.35	152	0.73	0.52	0.49
		81	0.68	0.21	0.2	84	0.73	0.44	0.45
		36	0.69	0.22	0.21	37	0.72	0.35	0.4

5 Conclusion and Future Work

In this paper we presented the first results of a long term project whose goal is to build systems which see, perceive and interact in open world environments like humans. Our results show that FOLLOWER is capable of progressively memorizing novel objects, even in complete absence of supervision, and that a developmental strategy is highly beneficial in boosting its performance and reducing its need for human supervision.

In this line of thinking we see as strategic the possibility to make this work more semantics and knowledge-aware, this being the basis for a meaningful interaction with humans. The key choices underlying this work (i.e., the exploitation of persistence, the choice of a similarity-based approach and the attention to incrementality) were indeed motivated by this intuition. The use of similarity and the focus on the instance-level allow for the adaptability to an open world, with instance-level recognition naturally scaled to the perception of classes. The choice of the right granularity can be adapted in an

object-dependent way in order to contain the ever increasing memory footprint, which is the cost to pay if the algorithms must keep recognizing more and more new objects. Another approach would be to let the user decide what she is interested in, keeping in memory only information on the objects she cares, dropping or merging the uninteresting objects. This latter way highlights a key aspect of the egocentric recognition, a setting where the classification capabilities of the machine is tailored to fit the needs of a single human.

ACKNOWLEDGEMENTS

This research has received funding from the European Union’s Horizon 2020 FET Proactive project WeNet The Internet of us, grant agreement No 823783.

REFERENCES

- [1] A. Bendale and T. E. Boulton, ‘Towards open world recognition’, in *CVPR*, pp. 1893–1902, (2015).
- [2] A. Bendale and T. E. Boulton, ‘Towards open set deep networks’, in *CVPR*, pp. 1563–1572, (2016).
- [3] Y. Bengio, J. Louradour, R. Collobert, and J. Weston, ‘Curriculum learning’, in *ICML, ICML ’09*, pp. 41–48, (2009).
- [4] E. Clerkin, E. Hart, J. Rehg, C. Yu, and L. Smith, ‘Real-world visual statistics and infants’ first-learned object names’, *RSTB*, **372**, (2017).
- [5] J. Deng, W. Dong, R. Socher, L. Li, K. Li, and L. Fei-Fei, ‘Imagenet: A large-scale hierarchical image database’, in *CVPR*, pp. 248–255. IEEE, (2009).
- [6] P. Fldik, ‘Learning invariance from transformation sequences’, *Neural Computation*, **3**(2), 194–200, (1991).
- [7] A. Gepperth and C. Karaoguz, ‘A bio-inspired incremental learning architecture for applied perceptual problems’, *Cognitive Computation*, **8**(5), 924–934, (2016).
- [8] I. J. Goodfellow, M. Mirza, D. Xiao, A. Courville, and Y. Bengio, ‘An empirical investigation of catastrophic forgetting in gradient-based neural networks’, in *ICLR*, (2014).
- [9] K. He, X. Zhang, S. Ren, and J. Sun, ‘Deep residual learning for image recognition’, in *CVPR*, pp. 770–778, (2016).
- [10] S. KIRSTEIN, A. DENECKE, S. HASLER, H. WERSING, H. GROSS, and E. KÖRNER, ‘A vision architecture for unconstrained and incremental learning of multiple categories’, *Memetic Computing*, **1**(4), 291, (2009).
- [11] G. Koch, ‘Siamese neural networks for one-shot image recognition’, in *ICML Deep Learning Workshop*, (2015).
- [12] H. Lee, J. Huang, M. Singh, and M. Yang, ‘Unsupervised representation learning by sorting sequences’, in *ICCV*, pp. 667–676. IEEE, (2017).
- [13] W. Li, X. Zhu, and S. Gong, ‘Harmonious attention network for person re-identification’, in *CVPR*, pp. 2285–2294, (2018).
- [14] V. Lomonaco and D. Maltoni, ‘Core50: a new dataset and benchmark for continuous object recognition’, in *CoRL*, volume 78, pp. 17–26. PMLR, (13–15 Nov 2017).
- [15] N. Mishra, M. Rohaninejad, X. Chen, and P. Abbeel, ‘A simple neural attentive meta-learner’, in *ICLR*, (2018).
- [16] I. Misra, C. L. Zitnick, and M. Hebert, ‘Shuffle and learn: unsupervised learning using temporal order verification’, in *ECCV*, pp. 527–544. Springer, (2016).
- [17] T. Nakamura, K. Sugiura, T. Nagai, N. Iwahashi, T. Toda, H. Okada, and T. Omori, ‘Learning novel objects for extended mobile manipulation’, *Robotic Systems*, **66**(1-2), 187–204, (2012).
- [18] L. Nuo and J. J. DiCarlo, ‘Unsupervised natural experience rapidly alters invariant object representation in visual cortex’, *Science*, **321**(5895), 1502–1507, (sep 2008). PMID: 18787171.
- [19] M. Oliveira, L. S. Lopes, G. H. Lim, S. H. Kasaei, A. M. Tomé, and A. Chauhan, ‘3d object perception and perceptual learning in the race project’, *Robotics and Autonomous Systems*, **75**, 614–626, (2016).
- [20] G. I. Parisi, R. Kemker, J. L. Part, C. Kanan, and S. Wermter, ‘Continual lifelong learning with neural networks: A review’, *arXiv preprint arXiv:1802.07569*, (2018).
- [21] A. Prest, C. Leistner, J. Civera, C. Schmid, and V. Ferrari, ‘Learning object class detectors from weakly annotated video’, in *CVPR*, pp. 3282–3289. IEEE, (2012).
- [22] J. Redmon, S. Divvala, R. Girshick, and A. Farhadi, ‘You only look once: Unified, real-time object detection’, in *CVPR*, pp. 779–788, (2016).
- [23] X. Ren and M. Philipose, ‘Egocentric recognition of handled objects: Benchmark and analysis’, in *CVPR Workshop*, pp. 1–8. IEEE, (2009).
- [24] E. M. Rudd, L. P. Jain, W. J. Scheirer, and T. E. Boulton, ‘The extreme value machine’, *TPAMI*, **40**(3), 762–768, (2018).
- [25] O. Russakovsky, J. Deng, H. Su, J. Krause, S. Satheesh, S. Ma, Z. Huang, A. Karpathy, A. Khosla, M. Bernstein, et al., ‘Imagenet large scale visual recognition challenge’, *IJCV*, **115**(3), 211–252, (2015).
- [26] A. Santoro, S. Bartunov, M. Botvinick, D. Wierstra, and T. Lillicrap, ‘Meta-learning with memory-augmented neural networks’, in *ICML*, pp. 1842–1850, (2016).
- [27] W. J. Scheirer, A. de Rezende Rocha, A. Sapkota, and T. E. Boulton, ‘Toward open set recognition’, *TPAMI*, **35**(7), 1757–1772, (2013).
- [28] Y. Shen, T. Xiao, H. Li, S. Yi, and X. Wang, ‘Learning deep neural networks for vehicle re-id with visual-spatio-temporal path proposals’, in *ICCV*, pp. 1918–1927. IEEE, (2017).
- [29] D. Skočaj, M. Kristan, A. Vrečko, M. Mahnič, M. Janiček, G. M. Kruijff, M. Hanheide, N. Hawes, T. Keller, M. Zillich, et al., ‘A system for interactive learning in dialogue with a tutor’, in *IROS*, pp. 3387–3394. IEEE, (2011).
- [30] L. B. Smith and L. K. Slone, ‘A developmental approach to machine learning?’, *Frontiers in Psychology*, **8**, 2124, (2017).
- [31] J. Snell, K. Swersky, and R. Zemel, ‘Prototypical networks for few-shot learning’, in *NIPS*, pp. 4080–4090, (2017).
- [32] E. Triantafillou, R. Zemel, and R. Urtasun, ‘Few-shot learning through an information retrieval lens’, in *NIPS*, pp. 2255–2265, (2017).
- [33] H. Wersing, S. KIRSTEIN, M. GÖTTING, H. BRANDL, M. DUNN, I. MIKHAILOVA, C. GOERICK, J. STEIL, H. RITTER, and E. KÖRNER, ‘Online learning of objects in a biologically motivated visual architecture’, *Neural Systems*, **17**(04), 219–230, (2007).
- [34] Y. Wu, Y. Lin, X. Dong, Y. Yan, W. Ouyang, and Y. Yang, ‘Exploit the unknown gradually: One-shot video-based person re-identification by stepwise learning’, in *CVPR*, pp. 5177–5186, (2018).
- [35] J. Yoon, E. Yang, J. Lee, and S. J. Hwang, ‘Lifelong learning with dynamically expandable networks’, in *ICLR*, (2018).
- [36] F. Zenke, B. Poole, and S. Ganguli, ‘Continual learning through synaptic intelligence’, in *ICML*, pp. 3987–3995, (2017).