

## Implementation of a multi-criteria and performance-based procurement procedure for energy retrofitting of facades during early design



Pascal Vullo<sup>a,\*</sup>, Alessio Passera<sup>a</sup>, Roberto Lollini<sup>a</sup>, Alessandro Prada<sup>b</sup>, Andrea Gasparella<sup>b</sup>

<sup>a</sup> Eurac research, Institute for Renewable Energy, Bolzano, Italy

<sup>b</sup> Free University of Bozen-Bolzano, Faculty of Science and Technology, Bolzano, Italy

### A B S T R A C T

Decisions taken during the early design of facade retrofits have a major influence on the final performance of buildings. However, current procurement procedures do not promote the evaluation of how facade systems design affects the overall building performance, which includes energy efficiency, comfort, cost and their complex interactions. Tenders are commonly based on single values which describe single properties of facade components like thermal transmittances and solar gain factors and do not consider interrelation between these components, the dynamic behavior of buildings and specific local climate. This paper presents a concept to drive public procurement processes based on overall building performance criteria. The methodology is operationalized by a user-friendly tool (FIT) predicting the overall performance according to facade design variations. These performance criteria are integrated into tenders by calculating a total score for every design proposal. This approach sensitizes designers and contracting authorities to consider the overall performance of a facade from the very early design and helps in making informed design decisions. An application in a simulated case study of a public school building shows its potential to guide public procurement processes and that further research and validation in actual procurement procedures is needed.

### 1. Introduction

Energy efficiency in buildings has been gaining importance everywhere in Europe. The Energy Performance of EU Buildings Directive (2010/31/EU) requires all new buildings to be nearly zero-energy by the end of 2020, and all new public buildings must be nearly zero-energy by 2018. Furthermore, since 2014 EU member states have started requiring in their building regulations and codes the use of minimum levels of energy from renewable sources in new buildings and in existing buildings that are subject to major renovation (Renewable Energy Directive, 2009/28/EC). This means that public authorities have the fundamental role to demonstrate the implementation of energy efficiency measures in their public buildings.

Public buildings in South Tyrol owned by the autonomous province of Bolzano (Bozen) account for almost 450,000 m<sup>2</sup>. Most of these buildings are schools, hospitals and office buildings. These three categories of buildings are responsible for 75% of consumed primary energy by the non-residential public building stock. 50% of these buildings were built before the 1970's (Citterio and Fasano, 2009; ISTAT, 2011), hence without any legal requirement on energy efficiency that was first

introduced in Italy in 1976 (Legge del 30/04/1976 n. 373, *norme per il contenimento del consumo energetico per usi termici negli edifici.*, 07/06/1976). This creates a significant potential for retrofit.

The present paper deals with the impact of facade retrofit solutions on the energy performance, indoor comfort and investment cost of public buildings under renovation, focusing in particular on very early design stages. This is because the facade, together with the heating, cooling and ventilation system, is mainly responsible for the energy needs of a building and the comfort of occupants and since 20% of the design decisions taken during early design phases subsequently influence 80% of all design decisions (Bogenstätter, 2000). Dawood, Crosbie, Dawood, and Lord (2013) state that research is required to support architectural and construction professionals in considering energy efficiency of building design in early design stages, when the opportunity is still open to substantially improve the energy performance of the design.

Looking at public buildings, Kershaw states that poor design procurement procedures are among the relevant barriers for energy efficient design of public school buildings (Kershaw and Simm, 2014). The procurement of a refurbishment measure of a public building is subject

Abbreviations: FIT, Façade Indicators Tool; WWR, Window to Wall Ratio; HDD, Heating Degree Days; Uw, Thermal transmittance window; g, Solar gain factor

\* Corresponding author.

E-mail address: [pascal.vullo@eurac.edu](mailto:pascal.vullo@eurac.edu) (P. Vullo).

<https://doi.org/10.1016/j.scs.2017.09.029>

Received 21 April 2017; Received in revised form 29 August 2017; Accepted 25 September 2017

Available online 28 September 2017

2210-6707/ © 2017 Eurac Research. Published by Elsevier Ltd. This is an open access article under the CC BY-NC-ND license (<http://creativecommons.org/licenses/by-nc-nd/4.0/>).

to a tendering process. A study carried out by IDM Südtirol Alto Adige investigated some of the most recent public tenders in the Province of Bolzano and neighboring Province of Trento (Battisti, 2015). It emerged that façade retrofit design proposals are either solely based on qualitative-descriptive criteria or on single-quantitative values like thermal transmittance or the solar gain factor (Battisti, 2015).

However, from the value of these single-quantitative criteria you cannot directly deduce their effect on energy consumption and comfort due to “contradicting requirements” (Ostergard, Jensen, & Maagaard, 2016).

For instance, taking the solar gain factor (or g-value) of the windows it is unclear if a lower or higher value is making the building more efficient and what consequences the chosen solar gain factor has on comfort aspects like the daylight level in the building, glare or thermal comfort. In fact, for the choice of a suitable g-value a combination of parameters have to be considered: heating or cooling dominated climate, internal gains, window to wall ratio, shading systems etc.

What is currently missing in tender procedures are evaluation criteria that reveal how a set of façade component properties, including g-values and thermal transmittances (U-values), affects the overall building performance.

A solution seems to be to request a future energy or sustainability certification. However, since the level of information needed to evaluate if the design can meet certification requirements is insufficient at early design stages, this is not a suitable selection criterion for early design procurement procedures, (Nielsen, Jensen, Larsen, & Nissen, 2016).

Which criteria can we use to evaluate overall building performance due to facade retrofit during early design?

Computer based simulation tools are able to calculate a set of multi-criteria performance indicators that can be suitable. These indicators mainly regard energy efficiency and indoor environmental comfort aspects and take into consideration the dynamic behavior of buildings. However, these simulation tools usually require detailed knowledge of the software and significant skills in building physics. The reason is that many of the available tools are developed and used mainly by researchers for research purposes (Petersen and Svendsen, 2010).

Yet, people involved in façade design and the tender evaluation of public buildings are usually officials of public authorities, architects and technicians. These people often lack specific skills in building modelling and encounter challenges and obstacles when performing dynamic building simulations. Examples for these obstacles are time-consuming modelling, uncertainty and variability of design parameters, large design space and rapid change of design (Ostergard et al., 2016). This is particularly problematic during early design stages when designers are unlikely willing to invest much time and effort.

As a result, authors identified the general need for more simplified methods (Thuvander, Femenias, Mjörnell, & Meiling, 2012) and state that there is a lack of tools that provide active support in terms of timely feedback on performance implications and helping compare and rank multiple design variations and decision systems that assist less-experienced decision makers (Attia, Gratia, De Herde, & Hensen, 2015; Kanters, Horvat, & Dubois, 2014; Kolotsa, Diakaki, Grigoroudis, Stavrakakis, & Kalaitzakis, 2009; Ostergard et al., 2016).

A lot of effort has been put into the development of user-friendly modelling and calculation tools, based on sophisticated simulation engines.

Examples are the Commercial Building Energy Saver Toolkit (Hong, 2015), the Toolkit for Energy Efficient Retrofit Measures for Government Buildings (IEAECBCS, 2017) and COMFEN (Windows and daylighting – Lawrence Berkeley National Laboratories Selkowitz, Hitchcock, Mitchell, McClintock, & Settlemyre, 2014). Numerous other easy to use decision support tools for early design were developed for different specific purposes (Attia et al., 2015), for instance “New-Facades” (Ochoa and Capeluto, 2009), “iDbuild” (Petersen and Svendsen, 2010), or the “Renofase Diagnose Tool” (Steskens,

Vanhellemont, Roels, & Van Den Bossche, 2015). For a larger overview, Ostergard et al. reviewed simulation based decision-making tools. Ferreira, de Brito, and Pinheiro (2013) and Nielsen et al. (2016) reviewed and classified decision support tools for sustainable refurbishment. Examples for application are the “Renofase Diagnose Tool” that was applied in at least 13 renovation projects (Steskens et al., 2015) while Pombo, Allacker, Rivela, & Neila, 2016 applied a sustainability assessment approach to current most-preferred retrofit strategies for residential buildings in Madrid, Spain. Yet, to the authors’ knowledge none of the tools were designed for or applied to procurement procedures for public buildings. Here, these approaches have a big potential to improve overall building performance.

This paper proposes a methodology to drive early design public procurement processes based on overall building performance, with a focus on façade retrofitting. For this purpose, we fixed a set of performance indicators, used within a tailored easy-to-use decision support tool called FIT. FIT stands for “Façade Indicators Tool”. The tool is the basis for the implementation of public procurement procedures that evaluate the overall multi-criteria performance of a design with a dedicated score. The tool is designed for the most representative building typologies commissioned by the Province of Bolzano, common façade technologies and local alpine climates of the South Tyrol region.

The paper examines current tender frameworks, analyzes how a multi-criteria and performance-based procurement procedure can be integrated in existing tendering frameworks and discusses a workflow on how performance results of design variants can be calculated and aggregated to a final score.

The tool and methodology do not claim to be validated and fully mature but are ready to be tested in real tenders for public buildings in collaboration with the Autonomous Province of Bolzano. This way it constitutes a first step towards performance based public procurement starting from very early design assessment and with the prospective to supply tools and methods for all design stages.

The potential of the method to support decision-making during the tendering process is demonstrated in a simulated case study.

## 2. Proposal for multi-criteria and performance based procurement procedure

The first step for implementation of a performance based procurement procedure was the already mentioned examination of current procurement procedures for construction and preliminary design of public buildings in the autonomous provinces of Bolzano and Trento (Battisti, 2015). The province of Trento is a neighboring province with similar boundary conditions.

### 2.1. Review of the current tender framework

Tables 1 and 2 summarize nine examined study cases of refurbishment and new constructions that included the facade, six construction tenders and three design tenders starting from preliminary design. It emerged that two of six construction tenders and all design tenders only use prescriptive evaluation criteria. The others use performance criteria that demand minimal requirements for single façade properties like thermal transmittance and solar gain factor and set requirements for building certification like LEED (LEED Leadership in Energy Efficient Design) or the regional KlimaHaus/CasaClima certification (KlimaHaus Agentur). In this framework, multi-criteria performance indicators considering overall building performance will be implemented instead.

### 2.2. Integration of multi-criteria performance in current tenders

Figs. 1 and 2 show evaluation criteria that are exemplary for the examined construction and design tenders. They also illustrate the distribution of scores among categories in percent. For construction tenders about 25% of the score was dedicated to performance. In the

**Table 1**  
Examined construction tenders for facade retrofit of the province of Bolzano and Trento.

Nr.	Construction tender	Measure	Building type	Year	General criteria	Required certification
1	School WFO BRUNECK	Refurbishment	School	2013	Performance based – quantitative <sup>a</sup>	KlimaHaus B
2	Fire brigade VIERSCHACH	New Construction	Fire brigade	2013	Descriptive- qualitative	
3	School of Arts G. SORAPERRA POZZA DI FASSA	New Construction	School	2012	Performance based – quantitative <sup>a</sup>	LEED Gold
4	Hospital of SCHLANDERS	Refurbishment	Hospital	2012	Descriptive- qualitative	
5	COLLEGIO MAYER TRENTO	New Construction	Residential school	2011	Performance based – quantitative <sup>a</sup>	LEED Platinum
6	POLO MECCATRONICA ROVERETO	Refurbishment	Offices	2011	Performance based – quantitative <sup>a</sup>	LEED Silver

<sup>a</sup> with minimal requirements for single façade properties.

case of the assignment of the design, performance criteria are usually missing. Evaluation is only based on qualitative descriptions of project references and the organization of the design team (Battisti, 2015).

To conclude, for construction tenders single performance criteria like U and g-values, that merely describe single facade properties, should be replaced by criteria on overall building performance. In the case of design tenders, performance criteria are completely missing and have to be introduced. However, the scope is not only providing better evaluation criteria for the contracting authority, but also to make easier communication between contracting authority and designers by using a performance-based workflow, and a tool with a very user-friendly interface enabling involved players to calculate such performances.

### 2.3. Proposed performance evaluation workflow

The proposed tender procedure follows performance-based design principles. Performance-based design was formulated by Kalay (Kalay, 1999) and further explained by Petersen and Svendsen (Petersen and Svendsen, 2010). Performance-based design is a process where decisions are supported by quantitative performances whose calculation should be standardized and shared among the involved stakeholders. In the proposed performance evaluation workflow, contracting authority and designers run through an iterative process evaluating overall building performance.

Fig. 3 sketches the performance evaluation workflow using FIT. The contracting authority (i) considers the boundary conditions of the facade to be renovated to define the overall building target performance, (ii) thanks to FIT the authority observes the impact of facade parameters variations in terms of performance indicators (outputs), and finally (iii) sets the evaluation framework (reference values and weighting factors) of FIT. That is needed to calculate scores for the retrofit scenarios proposed by the design procurement applicants.

Following that the designers participating in the bid define the facade configuration to match the requirements set by the contracting authority. In the same way as the contracting authority, by using FIT, they can calculate the impact of possible different facade configurations on overall building performance.

Finally, the public authority defines a ranking of the design offers by using the weighted multi-criteria evaluation system. The tender winner is defined by coupling the performance score with other “conventional criteria” as illustrated in Fig.1 and Fig. 2.

The whole approach is based on performance indicators calculated by the Facade Indicators Tool.

**Table 2**  
Examined construction tenders for facade retrofit of the provinces of Bolzano and Trento.

Nr.	Design tender	Measure	Building type	Year	Project design phase	General criteria
1	Canteen school area BRUNECK	New construction	School canteen	2014	Preliminary	Descriptive- qualitative
2	Enlargement EURAC BOLZANO	New construction	Offices	2013	Preliminary	Descriptive- qualitative
3	MARTIN LUTHER KING SCHOOL BOLZANO	Refurbishment	School	2013	Preliminary, definitive and executive	Descriptive- qualitative

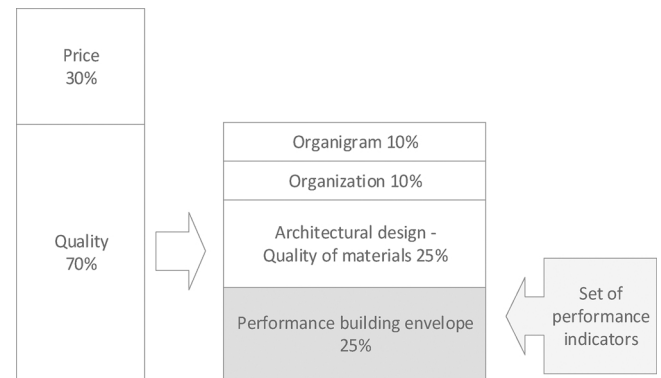

Fig. 1. Integration of performance criteria into construction procurement procedures.

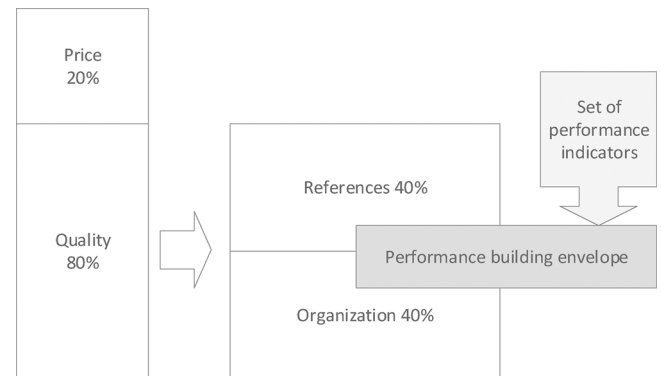

Fig. 2. Integration of performance criteria into design procurement procedures.

### 3. Development of a facade performance evaluation tool

FIT provides values of performance indicators by looking them up in a database of results of previously performed dynamic simulations. Simulations were run for several building models, different façade types and for a number of other input parameters. The simulation models describe the most relevant building and façade typologies emerging from the examination of public tenders of the provinces of Bolzano and Trento (Battisti, 2015) and representative local alpine climates. The building types are: school, office, and hospital.

Fig. 4 illustrates the development scheme of FIT. The authors emphasize that both weather data and reference building models can be replaced and modified to face specific contexts/cases and beyond that,

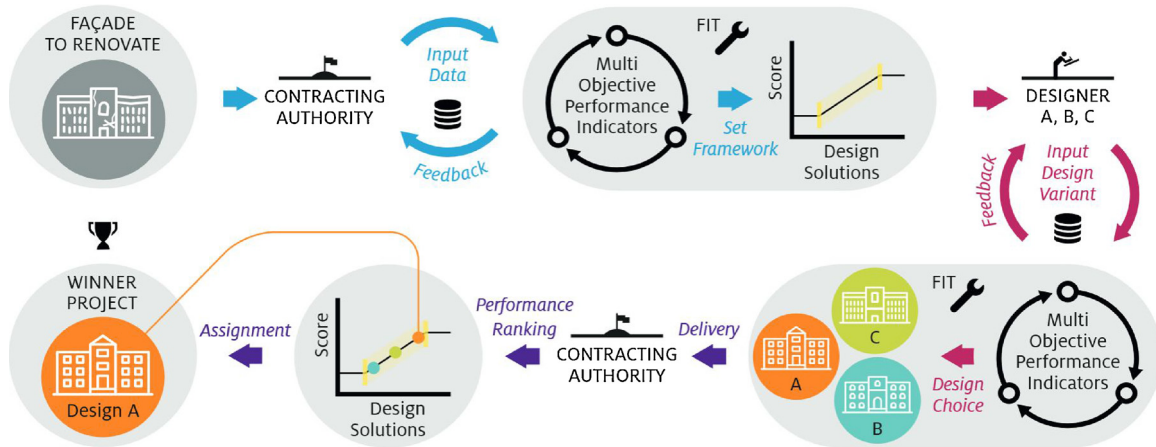

Fig. 3. Visualization of performance evaluation workflow.

models can be created specifically from case to case in a future development step. The following chapters describe in detail how the development scheme was implemented.

### 3.1. Building models

The building models were built up in EnergyPlus (EnergyPlus, 2017; U.S. Department of Energy, 2017), and are based on models developed in the framework of Commercial Reference Buildings Program financed by the US Department of Energy. The commercial reference building models are simulation models with reasonable realistic building characteristics, representative for different building typologies including representative geometries, size, building structure, occupancy schedules and internal gains (Commercial Reference Building Models of the National Building Stock, U.S. Department of Energy). From this choice of models were selected the ones that are most representative for

the three most frequent public building types in the province of Bolzano and their typical size, configuration, and shape: a mid-size rectangular shaped office building, a mid-size secondary school and a hospital were chosen. The heating system was replaced by an ideal heating system (“ideal loads system” EnergyPlus object) that maintains the temperatures above 20° and below 26°C. In the same way, facade models created ad hoc with three different window to wall ratios replaced the original facade models. A Matlab script was used to simulate the full-factorial design of all parameter combinations. The electricity production of potential photovoltaic systems installed on facade or on roof was estimated separately with PVGIS (Photovoltaic Geographical Information System PVGIS, European Commission, Joint Research Centre).

On the one hand, the reference buildings do not exactly represent the shape and size of average public buildings in South Tyrol, on the other hand they provide specific internal gain patterns of different

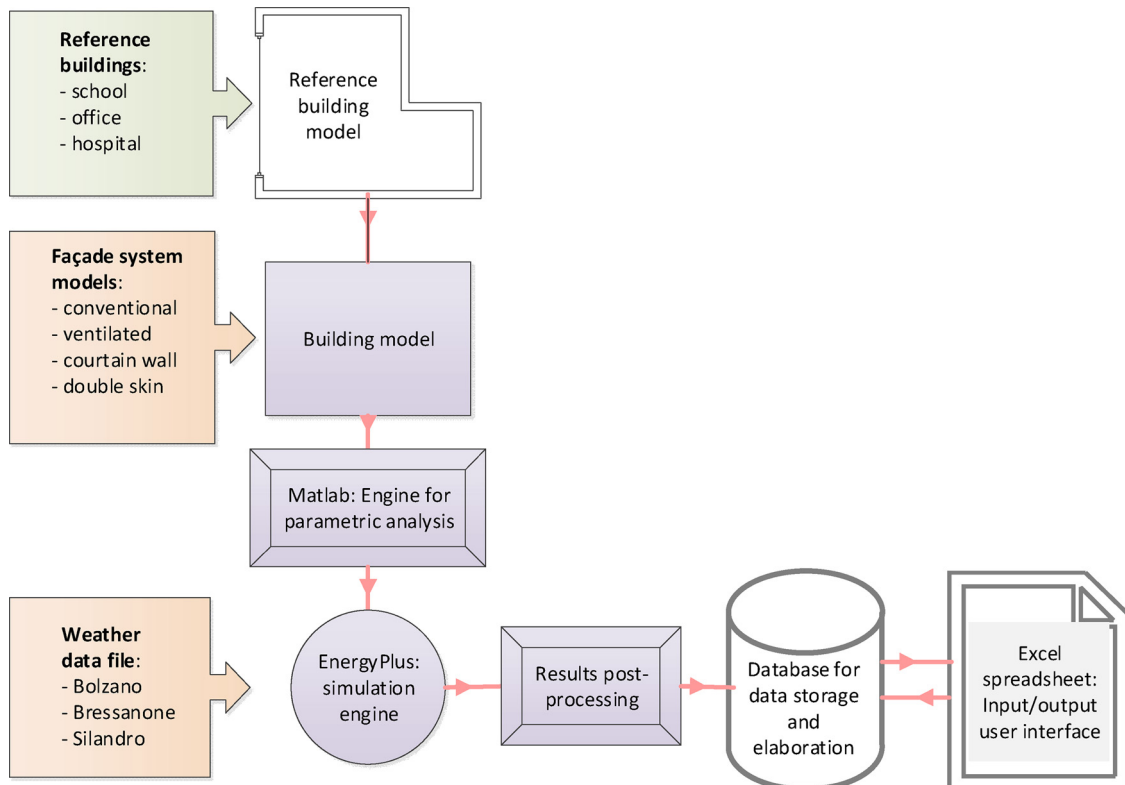

Fig. 4. Development scheme.

building uses like offices, schools and hospitals deriving from a large database. Orientation is not among the input parameters. However, outputs for thermal and visual comfort are provided for single reference rooms separately that represent different orientation and building uses, while outputs for energy demand are provided for the whole building, considering all orientations of the building model. It is important to note that it is not the aim of the authors to provide a realistic building model for every single case, but rather a suitable and standard testing environment to predict the impact of design decisions on facade performance for a set of standard conditions. It has to be considered that this method was designed for very early design stages. Specific boundary conditions like orientation of the main facade, detailed geometry of the building, shading of neighboring buildings, mountains or trees can partly be accounted for by choosing appropriate weighting factors. In the following design phases, after very early design, specific models shall be created including major details for every specific project.

### 3.2. Façade system models

Four façade typologies were investigated: A conventional solution with brick (massive wall) to be insulated from the inside or the outside, a ventilated façade with an external cladding, and two curtain wall systems: a single skin façade and double skin façade with 90 cm distance between the two skins. We used the “Exterior Naturally Vented Cavity” model of EnergyPlus for the airflow and the radiative heat exchange between the wall and the baffle of the ventilated façade. The “Air Flow Network” model and the “Full exterior and full interior” solar radiation model were used for the airflow of the double skin façade.

### 3.3. Input parameters

Table 3 shows the full range of input parameters. Most of them are directly describing the façade properties like the window to wall ratio (WWR) (Fig. 5). Other inputs like illumination power and infiltration are closely related to the façade and its performance. Requested infiltration input values refer to air change rates measured during a standard blower door test with 50 Pa pressure difference (EN 13829:2002, 2002 Thermal performance of buildings – Determination of air permeability of buildings – Fan pressurization method). These values are converted by the tool to average air exchange rates according to the EU standard EN 832 (DIN EN, 2017). In order to chose the fenestration model, the following inputs are demanded within a minimum and maximum range: thermal transmittance of the window, solar gain factor and visual transmittance. Subsequently the tool chooses the best fitting window model using a least error calculation considering weighting factors for all the three inputs. The selection of representative climate inputs (associated to the following cities/towns: Bolzano, Bressanone, Silandro and San Candido) is resulting from an enquiry at the Meteorological Service of the Autonomous Province of Bolzano (Wetterdienst der Autonomen Provinz Bozen)

### 3.4. Multi-criteria performance indicator outputs

The categories of performance indicator outputs and inputs of the tool are visualized in Fig. 6.

The benchmark model represents a typical existing building before retrofit with poor energy performance. It corresponds to an original building with a conventional facade without insulation and single glazing windows as illustrated in Table 4

#### 3.4.1. Energy related performance indicators

Table 5 illustrates the used energy related performance indicators.

The tool evaluates the annual energy demand for heating, cooling and lighting of the selected design. When a design tool indicates absolute values for energy demand, users intuitively expect these results

Table 3  
Input parameters.

BUILDING TYPE	Office building			School building			Hospital building		
	Conventional Façade WWR	Conventional Façade WWR	Conventional Façade WWR	Conventional Façade WWR	Ventilated Façade WWR	Curtain Wall WWR	Curtain Wall WWR	Double Skin Façade WWR	Double Skin Façade WWR
VARIABLES DEPENDING ON THE FAÇADE TYPOLOGY									
INPUT PARAMETERS	N°	20%	33%	50%	20%	50%	50%	100%	100%
Location/Climate (Heating Degree Days)	4	Bolzano (2791 HDD), Bressanone (3507 HDD), Silandro (3435 HDD), San Candido (4188 HDD)							
Infiltration	3	0.6, 2, 4 vol/h @ 50 Pa blower door test						2 vol/h @ 50 Pa blower door	
Illumination Power	3	7, 15, 25 W/m <sup>2</sup> (500 lx, continuous dimming, two sensors per zone on working plane)						15 W/m <sup>2</sup> (500 lx, c.d., two sensors)	
Insulation position	3	Absent, Inside, Outside			Absent, Outside			Absent, Outside	
Insulation resistance	8	3.25-5 in steps of 0.25m <sup>2</sup> /K/W			3, 3.5, 4, 4.5 m <sup>2</sup> /K/W			3.5 mK/W	
Insulation material (only for cost estimation)	9	Expanded Polyurethane, Extruded Polystyrene, Glass			Extruded Polystyrene + Graphite, Polyurethane Foam, Cork, Glass Wool, Rockwool, Wood Fiber, Cellular				
Fenestration	6	Single glazing, Low-e double glazing, Low-e double glazing (medium performance), Low-e double glazing (high performance)							
Shading system	3	Absent, Overhang over the window, Venetian blinds (“On if high radiation on window and cooling”, 300 W/m <sup>2</sup> , 45° tilt angle)							Venetian blinds (“On if h. r. o. w. a. c.”, 300 W/m <sup>2</sup> , 15° in cavity, 45° tilt angle)
Ventilated facade cladding	4	-			Absorbance/ emissivity: 0.25/0.45, 0.85/0.25, 0.85/0.6, 0.85/0.9				
PV technology	3	Amorphous Silicon, Crystalline Silicon, Thin Film							
PV surface on FAÇADE	-	The opaque facade portion of each flank (%) to covered with PV panels							
PV surface on ROOF	-	The roof surface area portion (%) to covered with PV panels (maximum value as function of tilt angle)							
PV exposure on ROOF	3	South, East/West, South-East/South-West							
PV tilt angle on ROOF	3	0°, 10°, 38°							

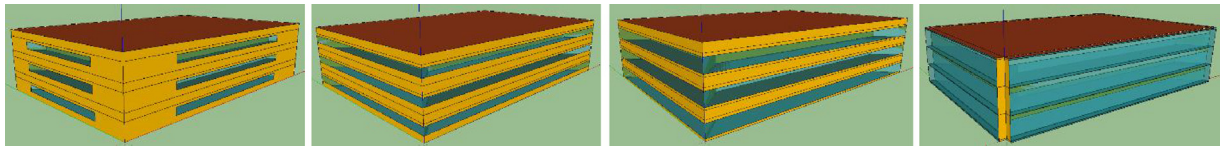

Fig. 5. Office building model with different window to wall ratios (WWR) implemented in FIT.

to be indicative of the final energy demand of the building. Since the aim of this early design tool is indeed to highlight performance differences between design solutions, results should not be mistaken for realistic results for the final building. Thus, energy related performance indicators are reported as relative values (in%) compared to a benchmark model. In later design steps, models that are more detailed are necessary, which can provide information about absolute values for the different indicators and confirm the design choices.

Minimized peak power leads to cost savings when the heating or cooling plant can be downsized. For this reason, the needed peak power for heating and cooling was considered as an additional performance indicator.

3.4.2. Visual and thermal comfort performance indicators

The outputs related to thermal and visual comfort refer to four representative detailed zones having different orientations for each one of the building models. Table 6 shows the four detailed zones for each building type. Fig. 7 shows the location of the detailed zones of the school model.

Table 7 illustrates the used thermal and visual comfort performance indicators.

Thermal comfort is calculated according to how far the Percentage of People Dissatisfied (PPD) of the Fanger thermal comfort model is from a 10% threshold value and the hours are summed up over the year. This approach allows a better evaluation of the differences in comfort between different models.

Table 4 Characteristics of benchmark model.

Parameter	Characteristics
Climate/location	For each location there is a benchmark model
Illumination power	25 W/m <sup>2</sup>
Façade typology	conventional
Insulation	Absent
Fenestration	Single glazing
Shading system	absent
PV integration	absent

Table 5 Energy related performance indicators.

	Performance indicator	Output in E+
Energy demand for lighting/heating/cooling	Annual energy demand compared to benchmark model (%)	Annual energy demand (kWh)
Needed peak power for heating/cooling	Peak power compared to benchmark model (%)	Peak power (W)

Two points are set on the work plane at 85 cm height to control the light intensity and assess the visual comfort: one is located close to the façade and the other one at two thirds of the room depth.

The Visual Discomfort Time counts the occupied hours that the

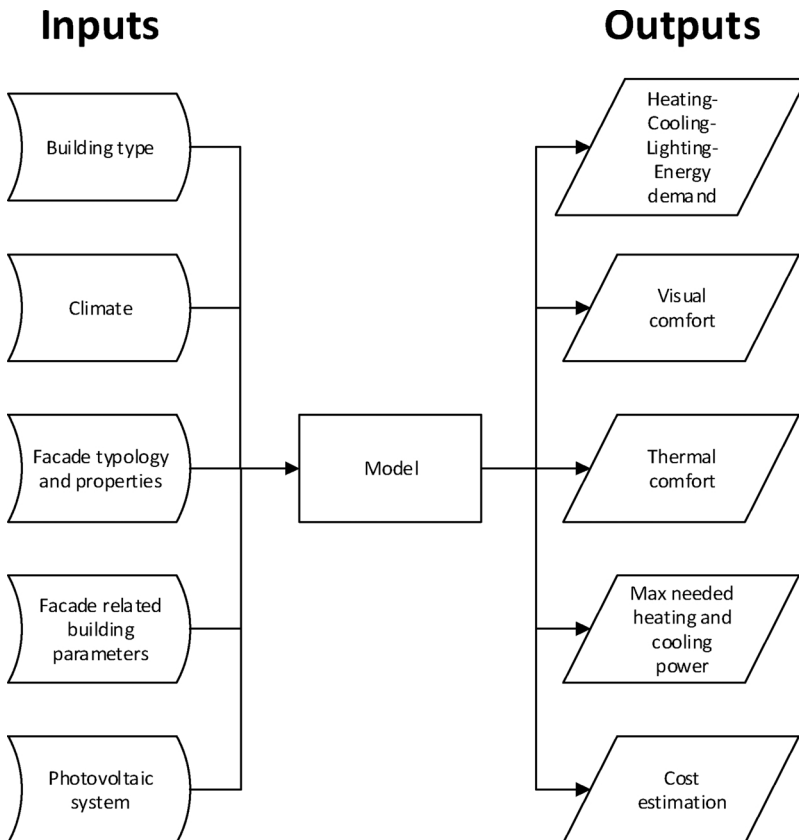

Fig. 6. Inputs and Outputs of FIT.

**Table 6**  
Detailed zones of models.

Office	School	Hospital
Office South	Class room South-West	Sick room East
Office East	Class room North-West	Sick room South
Office North	Library North-East	Sick room East
Office West	Office South-East	Sick room North

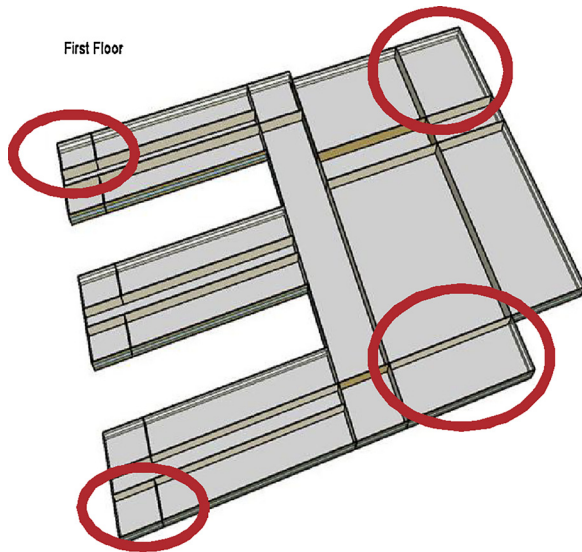

Fig. 7. Location of detailed zones of the school model.

**Table 7**  
Comfort performance indicators.

	Performance indicator	Output in E+	Threshold
Thermal comfort	Annual Weighted Thermal Discomfort Time [%]	Percentage of People Dissatisfied	10% of people dissatisfied
	Annual Visual Discomfort Time [%]	Daylight Glare Index	Office: 22; School: 20; Hospital: 18
Visual comfort	Annual Daylight Autonomy DA [%]	Illuminance	500 lx

Daylight Glare Index, calculated by EnergyPlus, exceeds a threshold value. The Daylight Autonomy (Reinhart, Mardaljevic, & Rogers, 2006) is the share of occupied hours when sufficient lighting is provided by daylight alone. For the calculation of the score, indicators are averaged for all measuring points or zones.

**3.4.3. Electricity demand coverage by photovoltaics**

The energy produced by photovoltaic panels installed on the façade and/or on the roof is assumed to be completely self-consumed. Indeed, no connection to the grid, hence feed-in tariff, was considered at this

stage. The ratio between produced and required electricity for lighting and cooling gives the demand coverage by photovoltaics, which was set as an output indicator. A different weight could be assigned to this indicator depending on the location of the building and the degree of integration into the façade.

**3.4.4. Cost estimation**

A cost estimation model for the investment cost of the retrofit measures was added as an additional feature based on the price index of the Province of Bolzano and price information of local manufacturers dealing with lighting systems, façade systems and building components (Richtpreisverzeichnis Hochbauarbeiten Autonome Provinz Bozen).

**4. Testing of the methodology in a case study**

The workflow of a hypothetical project is shown with the aim to demonstrate the application of the tool and its ability to guide the tendering process towards performance based design. In order to simplify and reduce the number of design parameters for this case study it was assumed that the retrofit concerns merely the exchange of the fenestration system.

**4.1. Case study description**

The case study is the secondary school “G. Carducci” located in Bolzano, see Fig. 8. It is a six-story building including two gyms, changing rooms, one basement floor and one floor half underground. The façade is made of prefabricated exposed concrete panels with generous fenestration. The windows are double-glazed with aluminum frame and warm edge spacer. The net floor surface area of the building is 9200 m<sup>2</sup>.

The school building simulation model taken from the Commercial Reference Buildings is reported in Fig. 9. The building has two stories above ground, no basement and a net floor surface area of 19500 m<sup>2</sup>. Every floor is composed of classrooms with long corridors and a compact part of the building with larger rooms including a library and a gym.

The window to wall ratios of the case study and the simulation model are 31.3% and 35% respectively, hence very similar.

At first sight, one could claim that the two buildings are not comparable from a morphological point of view. Yet, the concept is to use models of reference buildings that represent typical boundary conditions of a building typology, a typical mix of orientations and uses of rooms with corresponding internal gain schedules to provide not more than a sufficiently accurate modelling environment. This makes it possible to derive first conclusions on proposed façade system configuration performances in very early design stages.

**4.2. Application of the methodology**

**4.2.1. Workflow**

This chapter gives a detailed overview of the workflow proposed for the implementation of a multi-criteria and performance-based

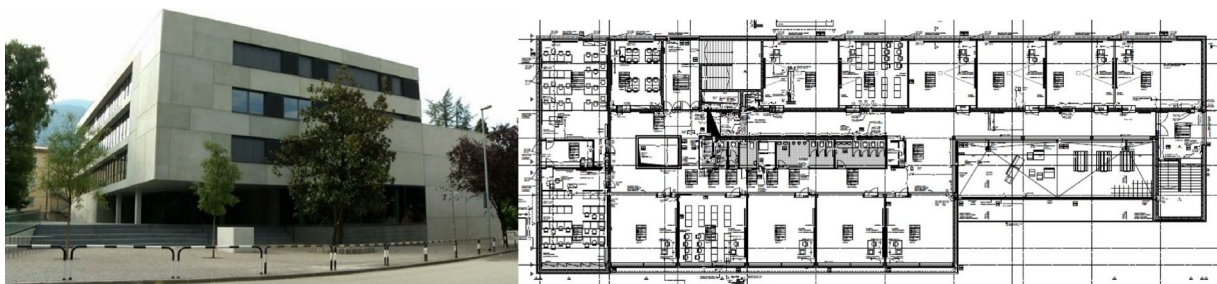

Fig. 8. View of the case study building from west and plan view.

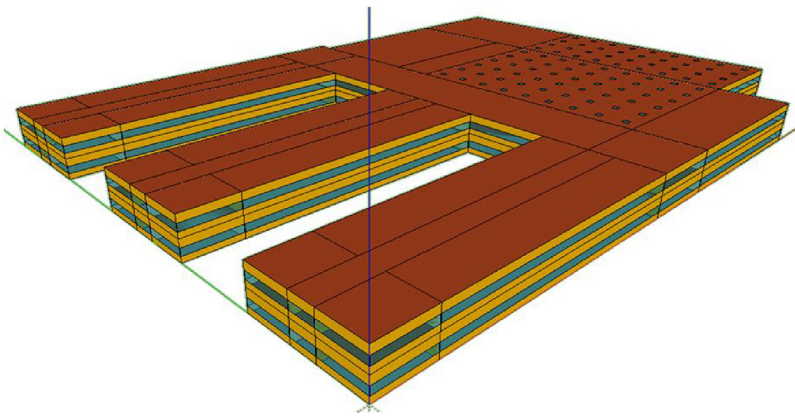

Fig. 9. Visualization of the school building simulation model.

**Contracting authority**

**Designer**

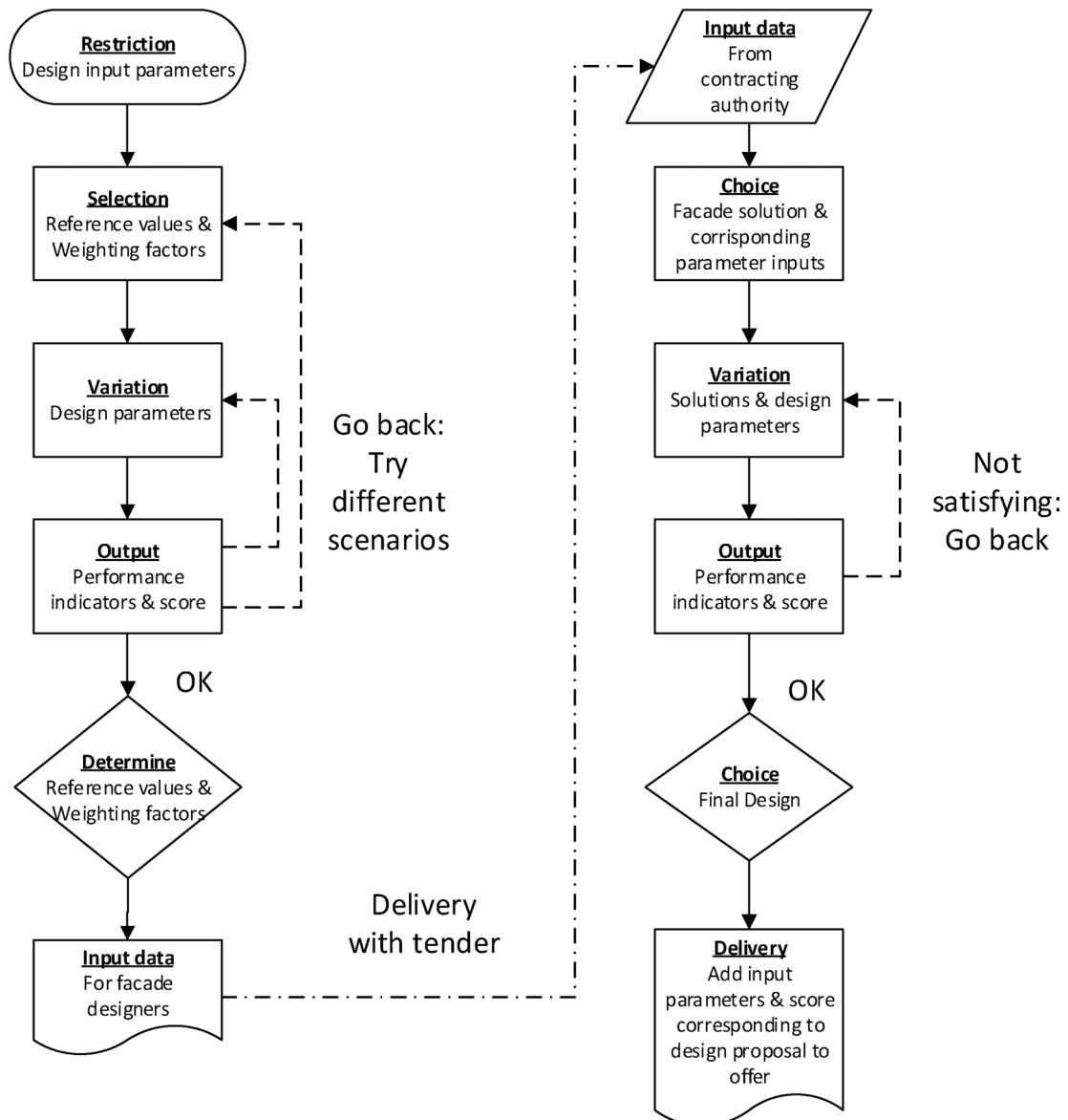

Fig. 10. Workflow of multi-criteria and performance-based procurement procedure for building facade retrofitting.



procurement procedure for building façade retrofitting as shown in Fig. 10.

- 1) The contracting authority uses FIT to set performance requirements in terms of an evaluation framework. First, the allowed input parameters are restricted depending on the boundary conditions of the refurbishment case (e.g. limitation of façade typologies to be used by the designers or setting of the efficiency of the existing lighting system) and according to possible design preferences. The score for every criterion is calculated by weighting and interpolation. Therefore, the task of the contracting authority is to set weighting factors and reference values. While the weighting factors are defined as the achievable maximal score for every evaluation criterion, the reference values are expressed as baseline and best-case values for every evaluation criterion that is used for interpolation of the score between 0 and the maximum achievable score. The authority varies the weighting factors and reference values, together with the design parameters, in order to examine their impact and to finally choose their values. The contracting authority gets immediate feedback by the tool during this process in the form of a score for every performance criterion and a total score that is the sum of the single scores of all criteria for each scenario. It undertakes several iterative loops and makes a final decision.
- 2) Designers get the parameter restrictions, the weighting factors and the baseline/best-case reference values as input, run through the definition of the building facade retrofitting, then choose the suitable related input parameters, which enable to describe at best their facade system, and add to their offer the score – calculated by the tool – that corresponds to their final design. Again, after every change of configuration the tool gives immediate feedback in terms of a score for every single performance criterion and a total score of the design. This information allows for informed and performance-based design decisions.

#### 4.2.2. Public authority

The first step in the workflow is the restriction of design parameters by the contracting authority. In this case study the existing facade is not affected. Therefore, parameters have to be chosen to approximate the existing facade and the existing building. See Table 8.

The scheme of score assignment depends on the “baseline” and “best-case” reference values and on the weighting factors. In the examined case study, the public authority has assigned the highest weight to heating since the school is not occupied during the long summer holidays. The public authority can adjust and optimize the “baseline”, and “best-case” reference values as well as the weighting factors according to its own preferences. The public authority therefore creates retrofit scenarios in the same way as the designer. See Chapter 4.3. The authority examines the impact of parameter variations on all performance indicators and the overall score. See Chapter 20. Finally the contracting authority integrates the final score into its overall assessment system visualized in Figs. 1 and 2.

**Table 8**  
Parameter restriction for the case study.

Parameter	Restriction
Climate	Bolzano
Window to wall ratio	35%
Facade	
Facade type	Conventional brick wall
Insulation	14 cm EPS R = 3.5m <sup>2</sup> K/W; U facade: 0.24 W/m <sup>2</sup> K
Insulation position	internal
n <sub>50</sub> blower door test	2 Vol/h (medium)
Installed lighting power	15 W/m <sup>2</sup> (medium)
Integrated Photovoltaic	NO

#### 4.2.3. Facade designer

The façade designer participating in the public competition is provided with the tool and the input parameters determined by the contracting authority. He/she examines his/her design proposal on multi-criteria performance and can analyze the impact of parameter variations in the same way as the public authority. Finally, the designer adds the score of his design and the chosen input parameters to their offer.

#### 4.2.4. FIT interface

FIT is a simple spreadsheet implemented in Microsoft Excel that provides outputs by looking up results in a database of previously performed simulations. The FIT interface allows an easy input of all variables in very little time. Figs. 11 and 12 display the implementation of a scenario.

#### 4.3. Retrofit scenarios

In order to explain the basic concept of the methodology in the exemplary retrofit scenarios only vary the properties of the fenestration system (Table 9). This is because we propose a workflow where during the design process a designer fixes some input parameters from the start and varies other parameters that the designer is disposed to modify or parameters whose impact on overall performance he/she wants to study. The first three retrofit scenarios examine the impact of adding different shading systems. First, we have added an overhang shading system and then compared it to external venetian blinds. The fourth variant additionally replaces a double pane low emissivity standard glazing with a high performance triple pane low emissivity glazing and combines it with external venetian blind shadings.

#### 4.4. Output and results

Table 10 shows the results of the four retrofit scenarios illustrated in Table 9. The rows represent the different performance indicators. Colored cells are inputs defined by the contracting authority. The columns show the “baseline” and “best-case” reference values as well as the “output” of the retrofit scenarios one to four. These input and output values are expressed in percent compared to the benchmark model or as percentage of the total hours of the year. Together with the “maximum score” input, a “score” is calculated for every indicator of every retrofit scenario by interpolation between “baseline” and “best-case” and multiplication with the “maximum score” of the indicator that functions as a weighting factor. Finally, the single scores of all categories are summed up to a “final score” for every retrofit scenario. In this example the contracting authority has set the “best-case” value to the best result in the category of all four design-variants. Instead, the “baseline” was set to a subjective acceptable minimum requirement level.

The results show how the introduction of an overhang on the one hand reduces energy demand for cooling and reduces glare but on the other hand decreases daylight autonomy and increases heating demand. The choice of venetian blinds equilibrates these effects. Adding a triple glazing further reduces heating demand, installed heating power as well as thermal comfort.

In case not only the fenestration system is affected by the refurbishment a designer, in further steps, will for instance want to examine the impact of position and thermal resistance of thermal insulation or the potential for coverage of the energy demand through roof mounted or façade integrated photovoltaics.

Table 11 aggregates the distribution of maximum reachable scores into macro categories for a better overview. However, the results are highly dependent on the choice of weighting factors and reference values of the scoring system. These have to be fine-tuned very carefully by the contracting authority.

##### 4.4.1. Impact of weighting factors and reference values

Table 12 explores the impact of weighting factors (in the left part)

## SCHOOL BUILDING

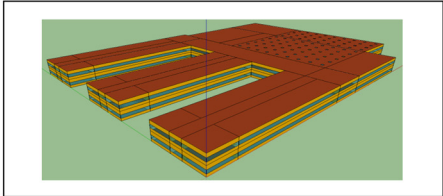
<b>Climate Zone/City</b>	<input type="text" value="Bolzano/Bozen"/>	▼	
<b>Facade Typology</b>	<input type="text" value="Cavity Wall"/>	▼	
<b>Window to Wall Ratio</b>	<input type="text" value="35 %"/>	▼	
			
<b>Envelope Air Tightness n50 Value</b>	<input type="text" value="2"/>	▼	ACH
<b>Lighting Power Density</b>	<input type="text" value="15"/>	▼	W m <sup>-2</sup>
<b>Shading System</b>			
<b>Overhang</b>	<input type="text" value="30"/>	▼	Degrees
<b>Venetian Blind</b>	<input type="text" value="No"/>	▼	

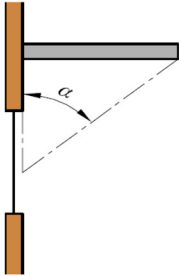

Fig. 11. Detail of the input part of the Excel tool: Definition of the climatic zone and building properties.

and reference values (in the right part) on the final score of the four retrofit scenarios (bottom). This final score is shown on the bottom for scenarios for the choice of weighting factors “contracting authority”, “heating dominated” and “cooling dominated” as well as for the reference values scenarios “contracting authority”, “worst” and “benchmark”.

Weighting factor scenarios:

- “cooling dominated” and “heating dominated” represent weighting factor scenarios where maximum importance is given to either cooling or heating power/energy demand.

Results show an important influence of the weighting factors on the final score and the ranking. Here, for the “cooling dominated” scenario the retrofit scenario without shading system is rated significantly worse than before while a window with fix overhang decreases solar gains most for the examined model. On the contrary, the “heating dominated” scenario shows the effect on the score when the overhang decreases solar gains in winter and points out how triple glazing lowers energy demand for heating.

- “contracting authority”: This is the scenario that was used in Table 10 where a virtual contracting authority tries to equilibrate weights and consider local needs of the case study.

Reference values scenarios:

- “worst”: This is a scenario where the baseline reference value is defined using the “worst of category” value for every performance indicator. In this way linear interpolation is done between the “worst of category” and the “best of category” value.
- “benchmark”: Here instead the benchmark model is used as baseline reference and interpolation is done between the “benchmark” value and the “best of category” value.

Again, results show an important influence also of the reference values on the final scores and the ranking. They show that the “benchmark” scenario decreases the differences and apart of the retrofit scenario without shading system all retrofit scenario perform very well, since the difference in performance of all retrofit scenarios compared to the benchmark model is very high. On the contrary using the “worst of category” value accentuates the differences in performance of

### FACADE DESIGN SOLUTION

Window Triple low-e glazing

			MIN	MAX	Insert desired values
<b>Thermal Transmittance <math>U_w</math> =</b>	0.728	$W m^{-2} K^{-1}$	0.728	1.793	0.8
<b>Solar Factor (g-value) =</b>	0.595	-	0.296	0.621	0.6
<b>Visible Transmittance =</b>	0.73	-	0.62	0.82	0.8

**Frame** Wood-Aluminium

**Insulation Position** External

**Insulation Thermal Resistance** 3.5

**Insulation Material** Extruded polystyrene

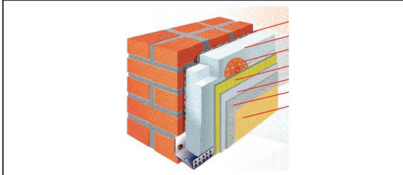

Thermal Conductivity = 0.04  $W m^{-1} K^{-1}$

Thickness = 14 cm

Wall Thermal Transmittance = 0.24  $W m^{-2} K^{-1}$

**Photovoltaic System**

**PV Module Technology** Polycrystalline Silicon

**Rear-side Ventilation** Effective Ventilation

**Facade surface area covered by PV (%)**

Exposure	PV/Opaque wall surface area	PV surface area [m <sup>2</sup> ]
South	10.0%	86
East	10.0%	39
West	10.0%	34

Fig. 12. Detail of the input part of the Excel tool: Definition of the window and building envelope properties.

Table 9  
Retrofit scenarios.

Retrofit scenario	Window systems				
	Uw	g	Visual transmittance	Glazing	Shading system
1	1.44	0.59	0.81	Double low-e glazing	Absent
2	1.44	0.59	0.81	Double low-e glazing	Overhang
3	1.44	0.59	0.81	Double low-e glazing	External venetian blinds
4	0.73	0.60	0.73	Triple low e glazing not tinted	External venetian blinds

the retrofit scenarios in the single categories.

- “contracting authority”: The “contracting authority” scenario is the one used in Table 10, where a hypothetical contracting authority tries to take the effects mentioned above into account and tries to define suitable subjective minimum performance requirements for every category for the specific case study.

In this study, the upper limit for interpolating remains the “best of category” value. Here the contracting authority determines the “best of category” values for all possible combinations of parameters free to the designers.

#### 4.4.2. Visualization

Several tables and charts were created to effectively communicate output details, see example in Fig. 13. A particular visual output is a cumulative distribution plot of the needed installed heating and cooling power over the year, see Fig. 14. The chart not only visualizes the needed peak power for heating and cooling compared to a benchmark model (see Table 4) but also its distribution over the year. The two diagrams are primarily helpful to understand the characteristics of the different energy needs of the examined building typology in its climatic context and the overall impact of retrofit measures on this characteristic rather than examining the impact of single parameter variations.

#### 4.4.3. Cost evaluation

Additional to the performance of the building, the investment cost of the measure can also be estimated in the evaluation tool. The result of the retrofit scenarios of Table 9 together with the final score of Table 10 is shown in Table 13. The cost estimation is scaled by the façade surface area and gives an impression of the extra cost for additional features of the windows. Table 13 suggests that in the examined

**Table 10**  
Score of design proposals. Pink: modifiable input by contracting authority.

Multi criteria performance indicators	BASE LINE	BEST	1		2		3		4		Maximum score
	Input	Input	Output	Score	Output	Score	Output	Score	Output	Score	
Energy demand for heating [kWh/m <sup>2</sup> a, % vs benchmark model]	30%	12.4%	13.4 %	<b>28.3</b>	16.0 %	<b>23.9</b>	13.5 %	28.1	12.4 %	<b>30.0</b>	<b>30</b>
Energy demand for cooling [kWh/m <sup>2</sup> a, % vs benchmark model]	50%	22.5%	38.6 %	<b>8.3</b>	22.5 %	<b>20.0</b>	29.6 %	14.8	30.0 %	<b>14.5</b>	<b>20</b>
Energy demand for lighting [kWh/m <sup>2</sup> a, % vs benchmark model]	70%	59.6%	59.6 %	<b>5.0</b>	113.4%	<b>0.0</b>	65.5 %	2.2	69.1 %	<b>0.4</b>	<b>5</b>
Heating Power [W, % vs benchmark model]	70%	49.2%	50.9 %	<b>4.6</b>	51.7 %	<b>4.4</b>	51.0 %	4.6	49.2 %	<b>5.0</b>	<b>5</b>
Cooling Power [W, % vs benchmark model]	50%	32.8%	38.6 %	<b>3.3</b>	32.8 %	<b>5.0</b>	34.3 %	4.6	33.9 %	<b>4.7</b>	<b>5</b>
Annual weighted thermal discomfort time [h, %]	50%	38.7%	51.5 %	<b>0.0</b>	68.2 %	<b>0.0</b>	43.6 %	8.5	38.7 %	<b>15.0</b>	<b>15</b>
Annual daylight autonomy, mean near to façade [h, %]	40%	71.5%	71.5 %	<b>5.0</b>	6.6 %	<b>0.0</b>	61.7 %	3.4	57.2 %	<b>2.7</b>	<b>5</b>
Annual daylight autonomy, mean distant from façade [h, %]	20%	44.4%	44.4 %	<b>5.0</b>	0.6 %	<b>0.0</b>	27.4 %	1.5	22.9 %	<b>0.6</b>	<b>5</b>
Annual visual discomfort time, mean near façade [h, %]	70%	36.0%	71.0 0%	0.0	36.0 0%	5.0	65.2 0%	0.7	62.1 %	1.2	<b>5</b>
Annual visual discomfort time, mean distant to façade [h, %]	70%	17.0%	62.4 0%	<b>0.7</b>	17.0 0%	<b>5.0</b>	58.5 %	<b>1.1</b>	56.5 %	<b>1.3</b>	<b>5</b>
Electric energy demand covered by PV on roof and façade integrated [kWh, %]	0%	15.0%	0.0%	<b>0.0</b>	0.0%	<b>0.0</b>	0.0%	<b>0.0</b>	0.0%	<b>0.0</b>	<b>0</b>
<b>Final Score</b>				<b>60.2</b>		<b>63.3</b>		<b>69.5</b>		<b>75.4</b>	<b>100</b>

**Table 11**  
Aggregation of reachable score into macro categories.

Macro category	Reachable score
Heating demand	30
Cooling demand	20
Max heating and cooling power	10
Thermal comfort	15
Energy demand for lighting, daylight and visual comfort	25
Sum	100

case study increased performance in terms of energy efficiency and comfort can justify additional investment in the façade system. Certainly, this is strongly dependent on the evaluation framework defined by the public authority as chapter 4.4.1 clearly points out.

Finally, the score related to the overall performance is integrated into the evaluation system of the procurement procedure, as illustrated in Figs. 1 and 2 as one of multiple other possible evaluation criteria defined by the public procurement.

## 5. Discussion and conclusion

### 5.1. Summary and main findings

The examination of current tenders for construction and design of public buildings in procurement procedures shows that an evaluation of overall building performance including energy efficiency, internal comfort, costs and their mutual interactions is missing. Multi-criteria performance indicators can bridge that gap.

The proposed methodology drives overall building performance-based public procurement processes by the implementation of performance indicators into tenders. This supports public authorities to award façade systems with the best overall performance. It allows for informed and performance based design and decision making by all stakeholders (technical staff of public authorities, designers, general contractors, suppliers) from the very early design stage.

The challenge was to define easy to use and reliable tools and methods for such a purpose.

**Table 12**  
Impact of weighting factors and reference values.

Multi criteria performance indicators	WEIGHTING FACTORS SCENARIOS					REFERENCE VALUES SCENARIOS			BEST	Maximum score
	BASE LINE	BEST	CONT. AUTH.	COOL. DOM.	HEAT. DOM.	CONT. AUTH.	WORST	BENCH MARK		
			Maximum score	Maximum score	Maximum score	BASE LINE	BASE LINE	BASE LINE		
Energy demand for heating [kWh/m <sup>2</sup> a , % vs benchmark model]	30%	12.4%	30	0	50	30%	16%	100%	12.4%	30
Energy demand for cooling [kWh/m <sup>2</sup> a , % vs benchmark model]	50%	22.5%	20	50	0	50%	39%	100%	22.5%	20
Energy demand for lighting [kWh/m <sup>2</sup> a , % vs benchmark model]	70%	59.6%	5	5	5	70%	113%	100%	59.6%	5
Heating Power [W , % vs benchmark model]	70%	49.2%	5	0	10	70%	52%	100%	49.2%	5
Cooling Power [W , % vs benchmark model]	50%	32.8%	5	10	0	50%	39%	100%	32.8%	5
Annual weighted thermal discomfort time [h , %]	50%	38.7%	15	15	15	50%	68%	100%	38.7%	15
Annual daylight autonomy, mean near to façade [h , %]	40%	71.5%	5	5	5	40%	21%	100%	71.5%	5
Annual daylight autonomy, mean distant from façade [h , %]	20%	44.4%	5	5	5	20%	2%	100%	44.4%	5
Annual visual discomfort time, mean near façade [h , %]	70%	36.0%	5	5	5	70%	71%	100%	36.0%	5
Annual visual discomfort time, mean distant to façade [h , %]	70%	17.0%	5	5	5	70%	62%	100%	17.0%	5
			<b>Final Score</b>			<b>Final Score</b>				
Retrofit scenario	1		60.2	43.1	72.1	60.2	46.8	86.3		
	2		63.3	70.0	58.6	63.3	35.0	98.9		
	3		69.5	63.6	73.4	69.5	62.4	94.0		
	4		75.4	66.9	81.2	75.4	76.8	96.8		

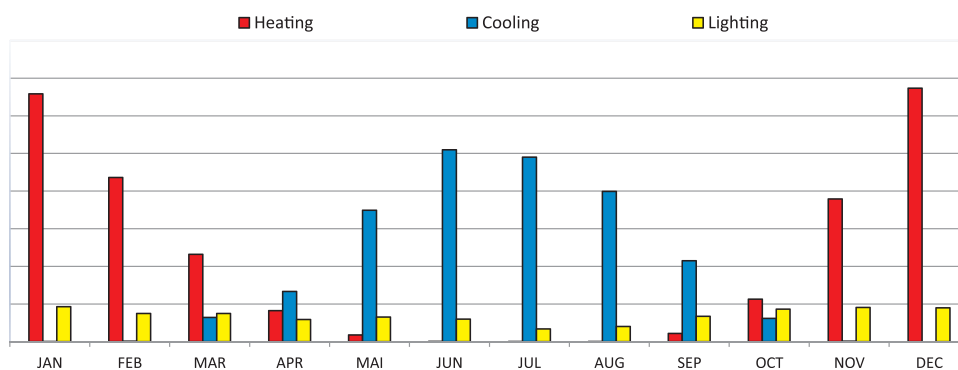

**Fig. 13.** Graphical output of FIT – Evolution and proportion of heating, cooling and lighting energy demand during the year.

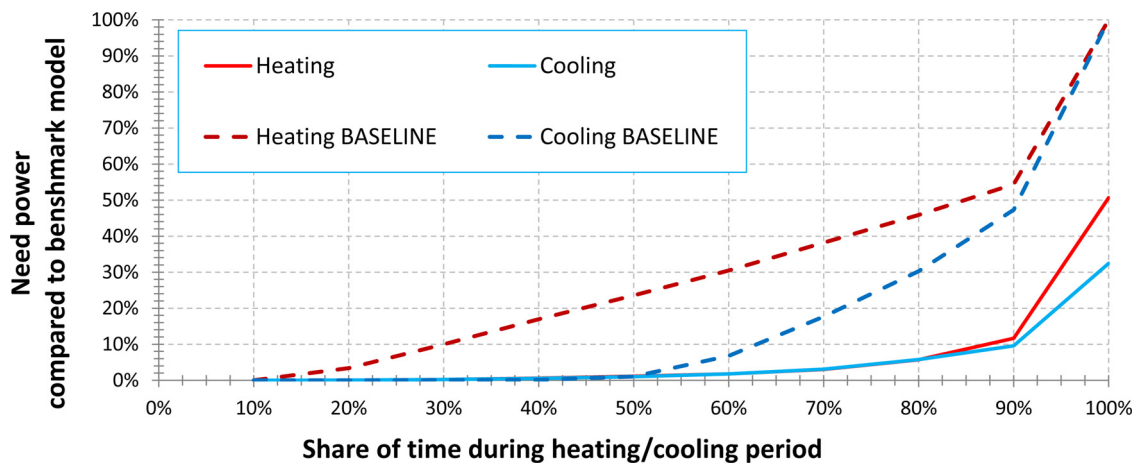

Fig. 14. Graphical output of FIT – Heating and cooling power demand: Frequency distribution and peak power.

**Table 13**  
Score and estimated investment cost of the measure.

	Retrofit scenario 1	Retrofit scenario 2	Retrofit scenario 3	Retrofit scenario 4
Final Score	60.2	63.3	69.5	75.4
Cost estimation [€/m <sup>2</sup> facade]	279	292	314	339

### 5.2. Strengths and limitations

The present study proposes a method to calculate and aggregate multi-criteria performance indicators based on dynamic building simulation and places at the disposal of users the tool “FIT” (Façade Indicators Tool) that is made of simple spreadsheets. FIT is providing multi-criteria performance indicators for a large set of design variants easily and rapidly. A workflow was defined to embed FIT as a decision support tool in performance-based public procurement processes.

The tool sheds light on how the modification of an input can improve one performance indicator and at the same time deteriorate another. This means that it identifies the trade-offs when requirements on comfortable and energy efficient design and cost have to be met at the same time. It also reveals how optimal design depends on boundary conditions like local climate and internal gain patterns that are linked to the building type. In this way, the method encourages designers to consider the impact of design decisions on different performance criteria and enables making informed design decisions.

At the same time, the contracting authority becomes an active part of the design and evaluation process. Because all stakeholders involved in public procurement processes use the same “FIT” tool this also eases communication among them.

The main advantage of the tool is its easily usable interface, giving immediate feedback about the impact of design variations. Designers can learn to handle the tool in a few minutes while providing results based on time consuming and complex dynamic simulations within a mouse click.

On the other side, it was necessary to use simplified models (regarding e.g. building shape, building orientation and shading by the surrounding area of the building or by mountains). However, the models provide a testing environment that is acceptable for early stage design and in order to test the method. Subsequently, adjusted models can be added to the database of FIT.

The application in a case study confirms that an awarding approach based merely on the investment cost can lead to a design choice with poor overall performance.

Here it also became clear that the contracting authority needs

adequate comprehension when defining the weighting factors, reference baseline, and best-case reference values since these are decisive for the calculation of the final score of the designs proposed by the designers.

This paper focuses on overall building performance as affected by the possible configurations of the façade system. Performances are calculated by dynamic building simulations, they include energy consumptions, indoor visual and thermal comfort, costs and the optional energy production by photovoltaic systems, while various supplementary performance criteria like sustainability indicators, safety or maintenance can be added to the evaluation scheme.

### 5.3. Comparison with existing tools and methods

Several decision-making support tools and methods for building construction and retrofit have already been developed. Some of them specifically focus on early design but none of them addresses procurement procedures of public buildings, which opens a research demand. This work presents an approach to drive overall building performance-based public procurement processes starting from very early design.

### 5.4. Future research

Additional work is needed on the evaluation procedure of design solutions, the choice of performance indicators and the calculation of a final score. Chapter 4.4.1 evidences that it remains a challenge for the contracting authority to choose weighting factors and reference values and to grasp their impact. However, this task can be seen as a learning process and should lead to an increase in competence of the technical staff working for the public body. In any case, it is important to underline that tools should remain flexible with regard to choosing and/or weighting criteria (Nielsen et al., 2016). Different methods can give valuable support to public authorities in choosing weighing factors that are appropriate for different building types. Among these methods are analytic hierarchy processes that are based on expert opinions or the simple and straightforward swing method. The implications of using one or another method should be discussed with the public authority.

High priority should be given to the application and testing of the proposed approach in real tenders. In this way, the tender process and the use of the tool are further optimized and parameters and criteria are identified that are necessary for acceptance by authorities and designers when it comes to practice. The objective is to enable an easy, comprehensive and substantiated comparison and evaluation of design variants. This optimization process needs additional feedback from designers and contracting authorities.

Finally, the tool is designed for very early design stages only. For implementing overall building performance criteria also in later design

stages, more detailed simulation models should be created ad hoc for specific projects and this approach tested likewise in real tenders.

## Funding

The Autonomous Province of Bozen-Bolzano funded this work within the collaborative research project “Capitolato Prestazionale Facciate”. The project activities were performed by Eurac research, Free University of Bozen-Bolzano, and IDM Südtirol-Alto Adige.

## Acknowledgments

The authors thank the Department of Innovation, Research and University of the Autonomous Province of Bozen-Bolzano for covering the Open Access publication costs.

## References

- Attia, S., Gratia, E., De Herde, A., & Hensen, J. L. M. (2015). Simulation based decision support for early stages of zero-energy building design. *Energy and Buildings*, *49*, 2–15.
- Battisti, C. (2015). rogetto CPF Capitolato prestazionale facciate–Attività WP 02–Definizione della procedura prestazionale dal committente al progettista fino alla realizzazione ed installazione. *Personal Communication*.
- Bogenstätter, U. (2000). Prediction and optimization of life-cycle costs in early design. *Building Reserch & Information*, 376–386.
- Citterio, M., & Fasano, G. (2009). *Indagine sui consumi degli edifici pubblici (direzionale e scuole) e potenzialità degli interventi di efficienza energetica*. ENEA.
- Dawood, S., Crosbie, T., Dawood, N., & Lord, R. (2013). Designing low carbon buildings: A framework to reduce energy consumption and embed the use of renewables. *Sustainable Cities and Society*, *8*, 63–71.
- DIN EN 832:2003–06, Thermal performance of building–Calculation of energy use for heating–Residential buildings.
- EN 13829:2002 (2002). *Thermal performance of buildings–Determination of air permeability of buildings - Fan pressurization method*. European committee for standardization.
- EnergyPlus, 2017. U.S. Department of Energy. Available: <https://energyplus.net/> [accessed 9.2.17].
- Ferreira, J., de Brito, J., & Pinheiro, M. D. (2013). Refurbishment decision support tools review ? Energy and life cycle as key aspects to sustainable refurbishment projects. *Energy Policy*, Vol. 62 [1453-14 + 0].
- Hong, T. (2015). Commercial building energy saver: An energy retrofit analysis toolkit. *Applied Energy*, 298–309.
- IEAECBCS (2017). *Annex 46–Energy efficient retrofit measures for government buildings*. 2011: Fraunhofer Institute for Building Physics [Available: [http://www.annex46.de/index\\_e.html](http://www.annex46.de/index_e.html)].
- ISTAT (2011). *Censimento popolazione abitazioni*.
- Kalay, Y. E. (1999). Performance-based-design. *Automation in Construction*, 395–409.
- Kanters, J., Horvat, M., & Dubois, M.-C. (2014). Tools and methods used by architects for solar design. *Energy and Buildings*, *68*, 721–731.
- Kershaw, T., & Simm, S. (2014). Thoughts of a design team: Barriers to low carbon school design. *Sustainable Cities and Society*, *11*, 40–47.
- KlimaHaus Agentur (2017). *KlimaHaus agentur*. Available: <http://www.klimahaus.it> [accessed 10.2.17].
- Kolotsa, D., Diakaki, C., Grigoroudis, E., Stavrakakis, G., & Kalaitzakis, K. (2009). Decision support methodologies on the energy efficiency and energy management in buildings. *Advances in Building Energy Research*, *3*, 121–146.
- LEED (2017). *Leadership in energy efficient design*. Available: <http://www.usgbc.org/leed> [accessed 10.2.17].
- Legge del 30/04/1976 n. 373 (1976). *norme per il contenimento del consumo energetico per usi termici negli edifici*. *Gazzetta Ufficiale ? Serie generale n. 148*. 4428 [07/06/1976].
- Nielsen, A. N., Jensen, R. L., Larsen, T. S., & Nissen, S. B. (2016). Early stage decision support for sustainable building renovation – A review. *Building and Environment*, *103*, 165–181.
- Ochoa, C., & Capeluto, I. G. (2009). Advice tool for early design stages of intelligent facades based on energy and visual comfort approach. *Energy and Buildings*, *41*, 480–488.
- Ostergard, T., Jensen, R. L., & Maagaard, S. E. (2016). Building simulations supporting decision making in early design – A review. *Renewable and Sustainable Energy Reviews*, *61*, 187–201.
- PVGIS (2017). *Photovoltaic geographical information system*. European Comission Joint Research Centre Available: <http://re.jrc.ec.europa.eu/pvgis/apps4/pvest.php#> [accessed 9.2.17].
- Petersen, S., & Svendsen, S. (2010). Method and simulation program informed decisions in the early stage of building design. *Energy and Buildings*, *42*, 1113–1119.
- Pombo, O., Allacker, K., Rivela, B., & Neila, J. (2016). Sustainability assessment of energy saving measures: A multi-criteria approach for residential buildings retrofitting ? A case study of the Spanish housing stock. *Energy and Buildings*, *116*, 384–394.
- Reinhart, C. F., Mardaljevic, J., & Rogers, Z. (2006). Dynamic daylight performance metrics for sustainable buildings. *Leukos*, *3*, 7–31.
- Richtpreisverzeichnis Hochbauarbeiten Autonome Provinz Bozen (2017). *Richtpreisverzeichnis hochbauarbeiten autonome provinz bozen*. Available: <http://www.provincia.bz.it/aov/richtpreise-hochbau-download.asp> [accessed 9.2.17].
- Selkowitz, S., Hitchcock, R., Mitchell, R., McClintock, M., & Settlemire, K. (2014). *COMPEN – Early design tool for commercial facades and fenestration systems*. LBNL.
- Steskens, P., Vanhellemont, Y., Roels, S., & Van Den Bossche, N. (2015). A decision making tool for the energy efficient refurbishment of residential buildings. *6th international building physics conference, IBPC 2015*.
- Thuvander, L., Femenias, P., Mjörnell, K., & Meiling, P. (2012). Unveiling the process of sustainable Renovation. *Sustainability*, *4*, 1188–1213.
- Department of Energy, U. S. (2017). *Commercial reference building models of the national building stock*. U.S. Department of Energy Available: <https://energy.gov/eere/buildings/commercial-reference-buildings> [accessed 9.2.17].
- Wetterdienst der Autonomen Provinz Bozen (2017). *Wetterdienst der autonomen provinz bozen*. [Available: <http://www.provinz.bz.it/wetter/home.asp>].
- Windows, & daylighting (2017). *Windows and daylighting*. Lawrence Berkeley National Laboratories Available: <https://windows.lbl.gov/software/comfen/comfen.html> [accessed 3.3.17].