

DISI - Via Sommarive 5 - 38123 Povo - Trento (Italy)
<http://disi.unitn.it>

AN INTERACTIVE PLATFORM FOR MULTILINGUAL LINGUISTIC RESOURCE ENRICHMENT

Ahmed Tawfik, Fausto Giunchiglia and Francesco Bux

August - 2014

Technical Report # DISI-14-018

Published in proceedings of KEOD 2014: International Conference on
Knowledge Engineering and Ontology Development. Rome, Italy, 21-24
October 2014.

An Interactive Platform for Multilingual Linguistic Resource Enrichment

Ahmed Tawfik, Fausto Giunchiglia and Francesco Bux

Department of Information Engineering and Computer Science,
University of Trento, via Sommarive 14 I-38123, Povo, Trento, Italy
{tawfik, fausto}@disi.unitn.it, francesco.bux@unitn.it

Abstract. The world is extremely diverse and its diversity is obvious in the cultural differences and the large number of spoken languages being used all over the world. In this sense, we need to collect and organize a huge amount of knowledge obtained from multiple resources differing from one another in many aspects. A possible approach for doing that is to think of designing effective tools for construction and maintenance of linguistic resources based on well-defined knowledge representation methodologies capable of dealing with diversity and the continuous evolvement of human knowledge. In this paper, we present a linguistic resource management platform which allows for knowledge organization in a language-independent manner and provides the appropriate mapping from a language independent concept to one or more language specific lexicalization. The paper explains the knowledge representation methodology used in constructing the platform together with the iterative process followed in designing and implementing the first version of the platform, named UKC-1 and the updated refined version, named UKC-2.

Keywords: Knowledge Representation, Knowledge Development and Maintenance, Knowledge Diversity, Multilingual Resources, User Interfaces.

1 Introduction

Nowadays, with the establishment of the internet technology in our daily life and the wish to obtain new knowledge from the huge amount of data, a new open data environment has been created. In this setting, public organizations, public entities and companies are the actors opening the huge archives of data, aiming to have tools to convert these data into useful knowledge. Among the set of open problems related to the management of this data, there is the one regarding the provenance of the entries, in particular, by being produced by actors coming from different countries around the world, the data are affected by the culture whose producer belongs to. This multicultural, hereinafter, multilingual environments, brings a matching problem, or an aggregation one (depending on the direction), coming from the fact that even if one entry has the same semantic meaning, each producer might represent it according to his own culture and language. Therefore, a solution to this problem would be the creation of a tool capable of mapping a piece of knowledge, or a semantic entry, in how this is represented according to a given language. This can be achieved by working at idiom level, namely by providing a mapping between the different entries of the languages themselves. Furthermore, the access to this linguistic network should be provided by an efficient application that should be flexible, cross-language and user friendly.

The Universal Knowledge Core, also referred to as UKC, is a framework designed and implemented by our research group which defines a methodology for organizing knowledge obtained from multiple languages into three main levels: (1) Natural language level, (2) Formal Language Level (3) knowledge level (Giunchiglia, F. et al. 2012a and Giunchiglia, F. et al. 2012b). Our main contribution in this paper is a web platform capable of providing linguistic analysis, enrichment and maintenance based on the UKC framework methodologies. Our main goal is to provide an efficient multilingual linguistic resource tool that facilitates the management of diversity across cultures and development of localized domain ontologies [Ganbold, A., Farazi, F. and Giunchiglia, F. (2014)]. The application was designed and implemented by following an iterative approach started by implementing a UKC WordNet application accessing the UKC together with the initial version of the application, named UKC-1. Then we conducted a comparative evaluation between UKC WordNet and the initial version UKC-1 in order to come up with a refined version of the application, named UKC-2.

The rest of this paper is organized as follows; Section 2 provides an overview of the UKC framework. Section 3 presents the UKC Wordnet View application, an application that resembles the famous WordNet application but has been designed and implemented internally by our research group. Section 4 presents the UKC-1 application, an application for accessing and manipulating the linguistic data stored in the UKC. Section 5 presents a comparative evaluation between UKC WordNet

View and UKC-1 application. Section 6 presents the UKC-2 application, a refined version of UKC-1 based on the results of the comparative evaluation between UKC Wordnet View and UKC-1. Section 7 summarizes the related work with main focus on applications and user interfaces designed for construction and maintenance of linguistic resources. Section 8 concludes the paper and points out to the future work.

2 Universal Knowledge Core Overview

WordNet [Fellbaum, C. (1998) and Miller, George A. (1995)] is a plain old standard, thus is affected by the cultural and social environment in which its development took place. Namely, the data present in WordNet belongs to one language only, British English, and the nature of the described entities reflects the British society and culture. Thus, in a multilingual and multicultural environment, it does not bring a real competitive advantage. On the other hand, the UKC provides a mapping between word forms (coming from different languages) and word meanings, indeed it is possible, given a concept, to see how this concept is expressed in different languages, or which synonymous sets are used to express that meaning in each language. A part from this lexical mapping, the UKC manages also semantic relations, which insist on more than one concept a part from the language. The semantic relations might vary on the base of the language - read culture - the concepts belong to. UKC is made up by different cores, but in this paper we are focusing only on the Natural Language Core and Concept Core, they represent the methodology behind the multilingual linguistic resource platform explained in this paper.

2.1 Natural Language Core

Natural languages are mainly composed of words. Each word in a natural language must have a distinct meaning, known as word sense, which refers to the context where the word is usually being used.

One possible approach for modeling a natural language could be as container of words sorted alphabetically. This approach might be useful for human beings interested in looking up the meaning of a specific word but for digital computers more information about words with similar or related meanings is needed in order to build efficient semantic aware and natural language processing applications.

The natural language core models a language as a huge container of *synsets* and *lexical gaps*. A synset is a set of words having the same word sense. A synset, in addition to being a set of synonym words, is also characterized by having a natural language gloss and a part of Speech (POS). The part of speech indicates whether a word is either noun, adjective, verb, or adverb. Figure-1 gives an example of the English word “kind” which has two different synsets. The first synset is associated

with three senses (form, sort, and kind) which correspond to the meaning of “Category of things”. The second synset is associated with one sense (kind) which corresponds to the meaning of “Someone having or showing tender or helpful nature”. In the same figure the Italian word “Gentile”, the translation of word kind, has one word sense and one corresponding synset.

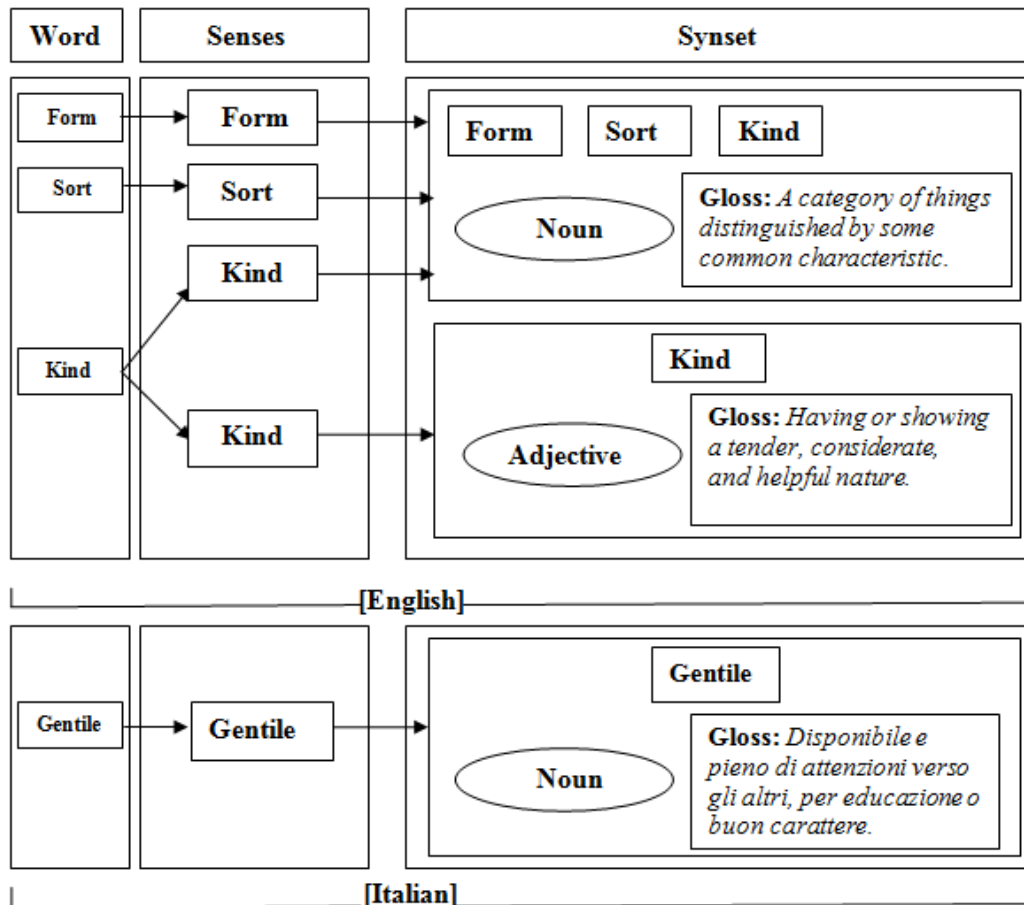

Figure-1: The relation between the English word “Kind”, its words senses, and synsets and the Italian word “Gentile”, and its words senses, and synsets.

Every synset is associated with one language-independent concept. It may happen that a language-independent concept has a corresponding synset in one language and a gap in another language, formally known as a *lexical gap*.

The relation between word senses is known as *lexical relations*. Natural language core defined 12 different types of lexical relations. Here, we explain briefly the most common types of lexical relations as an example: *Synonymy* and *Antonymy*. A Synonymy is a symmetric relation connecting two senses having the same Part of Speech and sharing the same meaning, i.e. early synonym soon. On the other hand,

an antonym is another symmetric relation connecting two senses having the same Part of Speech but having an opposite meaning, i.e. early antonym late.

2.2 Concept Core

The Concept Core is the codifying information about *language-independent concepts* and relations between them. Every synset in a natural language is associated with exactly one language-independent concept. Each concept is having a concept Id as a unique identifier and a concept label as a descriptive word obtained from the first language-dependent synset associated with the concept. Figure-2 gives an example of associating language-independent concepts to language-dependent synsets, together with the corresponding semantic relations between concepts.

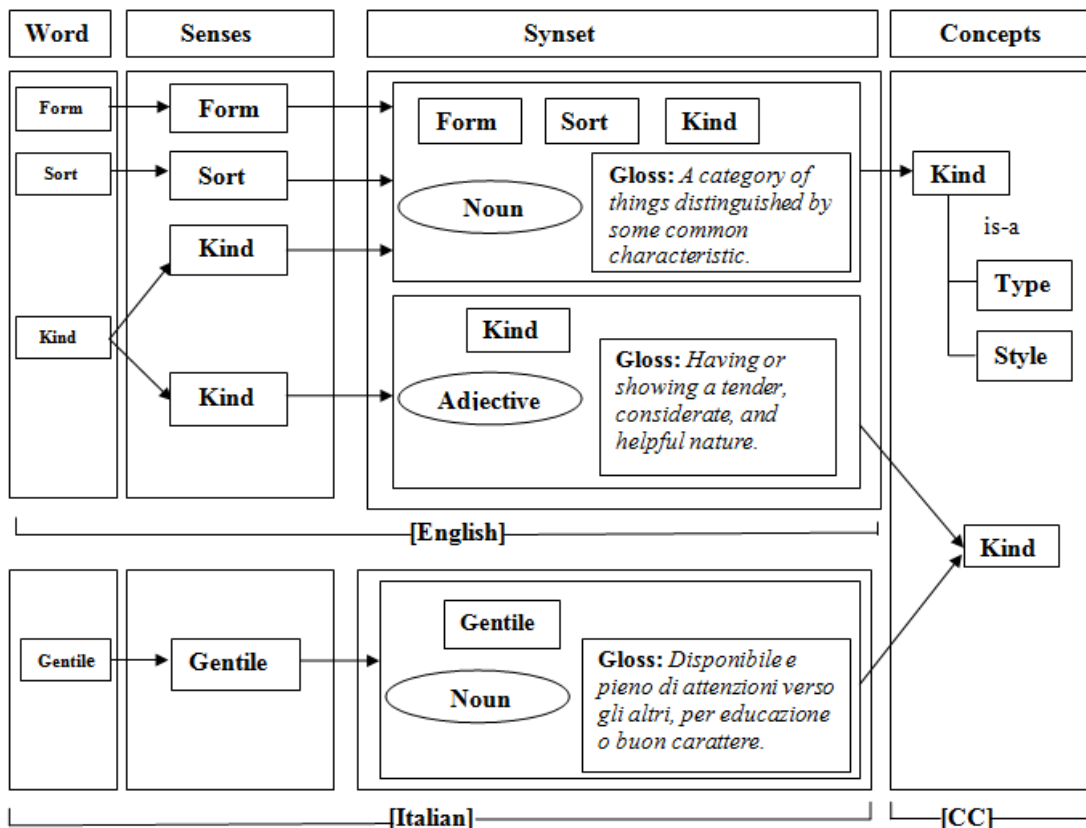

Figure-2: The relation between the English word “Kind”, its senses, and concepts and the Italian word “Gentile”, its sense and concepts. Knowing that concepts are language independent but in this figure we represent the concept labels in English.

Concepts are related to other concepts through *semantic relations*. There are two main types of semantic relations that may exist between concepts: *hierarchical relations* and *associative relations*. Hierarchical relations are those relations which are transitive and asymmetric. Concept core defined 5 different types of hierarchical relations. We explain briefly one of the most common hierarchical relations as an example, the *is-a* relation. The is-a relation is a specialization relation between two concepts that indicates the necessity of specialization, i.e. minivan is-a car. On the other hand, associative relations are those relations which connect concepts in different hierarchies in the Concept Core. Concept core defined 7 different types of associative relations. We explain briefly one of the most common associative relations as an example, the *has-member* relation. The has-member relation is a relation between concepts where the source denotes a set and the target is one of its members. i.e. car has-member automobile engine.

3. UKC WordNet View

UKC WordNet View application (Figure-3) is a web application provides access to the linguistic data stored in the UKC framework. An online demo is available at: <http://uk.disi.unitn.it:8089/ukcui/wordnetview.htm>.

The application has been designed to resemble the original user interface of WordNet (<http://wordnetweb.princeton.edu/perl/webwn>) after taking permission from the WordNet team; we sincerely thank them for that. The main idea behind designing an application that resembles the original WordNet is to fulfil the following goals: (1) Allow users who are familiar with WordNet to start accessing the UKC and rapidly get to know about its contents and main features. (2) Conduct a comparative evaluation between our UKC application and WordNet application while both accessing the same linguistic data source. The UKC WordNet View differs from the original WordNet in being a multilingual linguistic resource. For each word in a specific language, the application retrieves the synsets for the word from the natural language core together with the associated language-independent concepts from the concept core. Although, we have mapped the semantic and lexical relation names to the same relation names being used by the original WordNet application in order to maintain consistency with the original design. The application was also implemented following web 2.0 architecture so it's characterized by having interactive features like auto-completion and instant responsive behavior.

UKC Wordnet View

Home | Glossary | Help

Word to search for: Language:

Display Options:

Key: "S:" = Show Synset (semantic and semantic-lexical) relations, "W:" = Show Word (lexical) relations
 Display options for sense: (gloss) "an example sentence"

Noun

- **S: (n) kind, sort, form, variety** (a category of things distinguished by some common characteristic or quality) "sculpture is a form of art"
 - [direct hypernym / inherited hypernym](#)
 - [direct hyponym / full hyponym](#)

Adjective

- **S: (adj) kind** (having or showing a tender and considerate and helpful nature) used especially of persons and their behavior
 - [attribute](#)
 - [derivationally related form](#)
 - [similar to](#)
 - [antonym](#)
 - **W: (adj) unkind** (lacking kindness) "a thoughtless and unkind remark"
- **S: (adj) kind, genial** (agreeable, conducive to comfort) "a dry climate kind to asthmatics"
- **S: (adj) kind, tolerant** (tolerant and forgiving under provocation) "our neighbor was very kind about the window our son broke"

Figure-3: UKC WordNet View application.

Figure-3 shows the application user interface. The user can start a new search by typing a word and choosing the desired language. The application then retrieves the set of synsets organized by their part of speech (Noun, Adjective, Verb, and Adverb) and sorted by their synset rank. The user may interact with the retrieved synsets by clicking on the letter "S" next to the synset to show either semantic relations with the language-independent concept or semantic-lexical relations with language dependent synset. On the other hands, clicking on the letter "W" shows lexical relations with words. The user can modify the visual display for the displayed synsets by updating the display options. For each synset, it's possible to show or hide the: gloss, example sentences, synset provenance details, or the language-independent concept identifier for the concept associated with the synset.

4. UKC-1 Application

UKC-1 application is a web application for accessing and manipulating the linguistic data stored in the UKC. An online demo is available at <http://uk.disi.unitn.it:8089/ukcui/ukc.htm>.

The application was designed and implemented as a rich client internet application having the same instant responsive behavior, look and feel of desktop applications. In the next subsections, we explain briefly the application overall architecture and user interface design.

4.1 Overall Architecture

The overall architecture is a conceptual model that represents the main system components and data transfer between them. The overall architecture (Figure-4) was designed as a multi-layer (Model-View-Controller) architecture, commonly known as MVC pattern, a software design pattern for implementing user interfaces. The MVC architecture is divided into three main interconnected components in order to separate the application information and business logic from the ways that information is presented to the user.

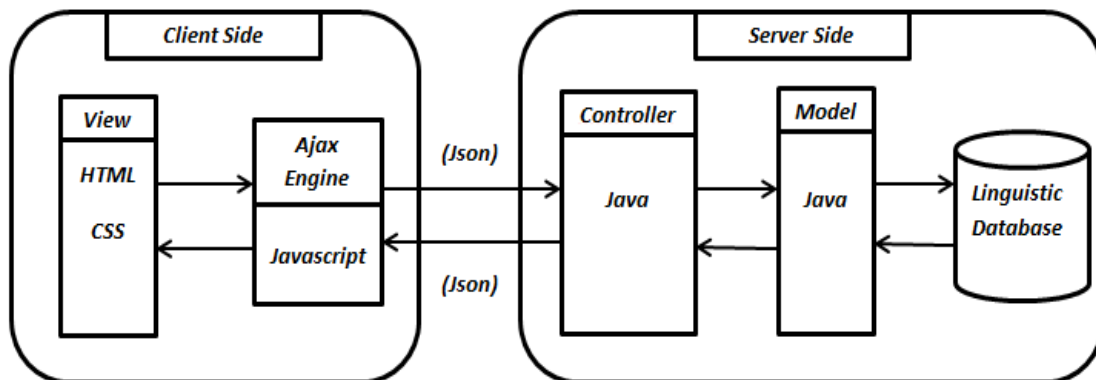

Figure-4: UKC-1 overall architecture.

In Figure-4, *the client side* is the user's browser environment. We have implemented two main components that run on the client side; View Component and Ajax Engine. The View component is responsible for data representation. The technologies used in data representation are: Hypertext Markup Language (HTML), the standard language for creating web pages, and Cascading Style Sheets (CSS), a style sheet language for formatting web pages. On the other hand, the Ajax Engine is the core of the web application which implements the application logic using JavaScript as a web programming language and JavaScript Object Notation (JSON) as a lightweight data-exchange format between the client and server. The Ajax Engine runs within the user's browser to ensure prompt responses to the user requests. The added engine eliminates the 'click and wait' nature of the classic web

applications and responds instantly to the user actions by exchanging data with the server behind the scenes without refreshing the web page.

In Figure-4, *the server side* is composed of two main components; the web controller and the application data mode, both components are using Java as a programming language. The web controller is responsible for handling communication with the client side through the Ajax Engine and submitting commands to the application data model for reading or updating application data. On the other hand, the application data model is the central location for application core data, business logic, and functions accessing the linguistic database.

4.2 User Interface

Figure-5 shows the application user interface. The user interface is divided into 5 main regions: (1) search panel (2) natural language core, named synsets panel (3) concepts core panel (4) expandable drawer used as linguistic reference panel, and (5) color legend at the bottom to differentiate between working and reference languages.

The top region where the user can start a new search by typing a word and choosing the desired working and reference languages respectively. The working language is the default language, when the user performs a search or an update operation; the system applies the changes based on the selected working language. The reference language is mainly for multilingual support in order to view the working language synset in another language or a lexical gap if there is no corresponding synset. The set of color legends at the bottom of the screen is used to differentiate between working language synsets (black font), reference language synsets (blue font). Another possible case when the language independent concept label is obtained from another language different from both working and reference languages. In this case, the concept label will be also retrieved and highlighted as a label from another language (red font). The synsets panel displays the content retrieved from the natural language core; the word synsets and their lexical and semantic lexical relations. The user can interact with the natural language core contents through the following user interface components:

- Toolbar at the top for manipulating the displayed synsets by performing Create-Update-Delete operations on synsets and their relations.
- Display manager for updating the visual display of the displayed synsets. For each synset, it's possible to show or hide the: synset gloss, example sentences, the language-independent concept identifier, or the corresponding synset in the reference language.
- Synset filtration capability for the displayed synsets, it's possible to filter synsets by part of speech or type of lexical relation.

- Viewing lexical and semantic relations from parent to child (sub-relations) or from child to parent (super-relations).
- Contextual (right-click) menu for providing handy way to retrieve synsets for synonym words and performing create/update/delete operations on synsets.

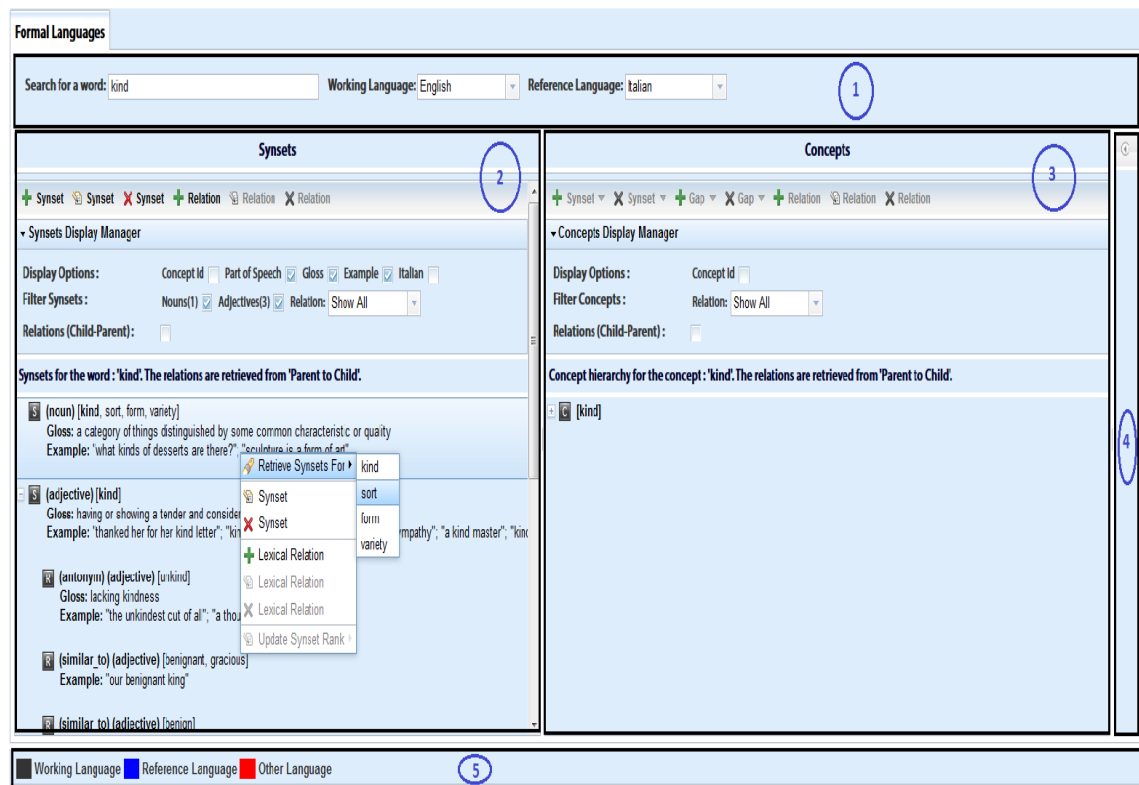

Figure-5: UKC-1 User Interface Design.

The concepts panel displays the content retrieved from the concept core; the language-independent concepts and their semantic relations. The user can interact with the concept core contents through the following user interface components:

- Toolbar at the top for defining new synset or lexical gap in the working or the reference language for the selected concept.
- Display manager for updating the visual display of the displayed concepts. For each concept, it's possible to show or hide the language-independent concept identifier.
- Concept filtration capability for the displayed concepts, it's possible to filter concepts by relation type.
- Viewing semantic-lexical relations from parent to child (sub-relations) or from child to parent (super-relations).

- Contextual (right-click) menu for providing handy way to create or delete synsets and lexical gaps and performing create/update/delete operations on semantic relations between concepts

A dynamic synchronization between the synsets panel and concepts panel regions takes place when the user selects any synset from the left region, the system automatically display the corresponding concept in the right region.

The expandable drawer on the right is used as a (read-only) linguistics reference panel. The purpose of this panel is to assist users while working on the main synsets and concepts panels in retrieving other sysnets or concepts and use them as a reference without the need to erase the contents of the main panels. The reference panel also assists user in creating new lexical and semantic relations through a drag and drop facility. For instance (Figure 6), a new lexical relation can be created by dragging a reference synset from the reference panel and dropping it over another synset from the main synsets panel.

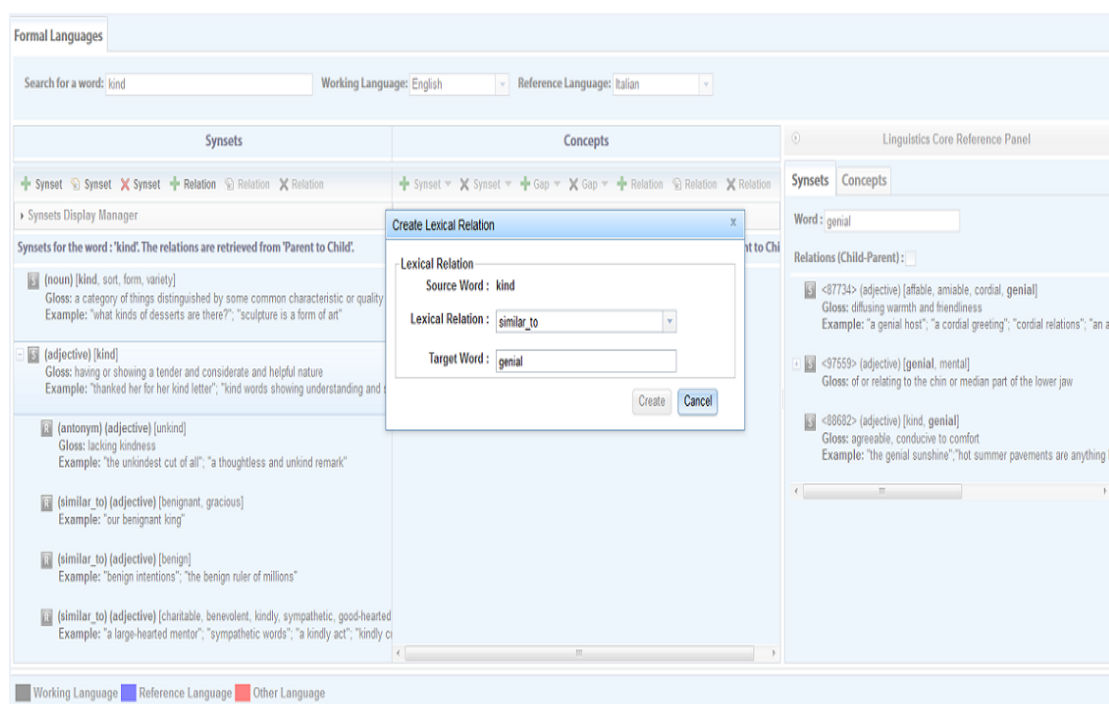

Figure-6: Linguistic Reference Panel provides drag and drop facility for creating lexical and semantic relations. The new lexical relation dialog popped up after dragging [genial, mental] synset from the reference panel and dropping it over the [kind] synset on the synsets panel.

Using the main and reference panels accompanied by toolbars and contextual menus together with the provided full control over the displayed information through the display managers, we should end up having an elegant linguistic analysis and manipulation tool which allow linguistic experts to enrich the available linguistic resources with minimal effort.

5. Comparative Evaluation (UKC-1 vs. WordNet View)

In order to improve the usability of the UKC view and knowing that the WordNet view is considered as the de-facto standard, we started by performing a comparative analysis between the two interfaces in order to elicit the usability problems on the view of the UKC. By being a comparative evaluation, it should be kept in mind that the two systems should share some meanings, some operation. In this case, even if the UKC view has been designed as a full Create-Retrieve-Update-Delete (hereinafter CRUD), while the WordNet view is a simple knowledge retrieval interface. Took this into account, the designed tasks for the evaluation, like the rest of the work, were built only around the retrieval features of the two interfaces.

5.1 Quantitative Work

On the base of these assumptions, and following the directives of Bodker [Bodker, S. (2000)], a quantitative analysis has been conducted to investigate how, in general, the user react to both views. For the quantitative work, the key points were three: tasks, questionnaires and measures. The main tasks that have been proposed to the testers were the following:

- Perform a search for an arbitrary word in an arbitrary language.
- Search for an arbitrary lemma in multiple idioms.
- Filter the results of a search process on the base of their Part-Of-Speech tag (hereinafter POS tag).
- Retrieve semantic relations insisting on a given concept.

5.2 Task Platform Work

The entire process of comparative analysis was supported by a custom-made platform capable of switching the two views shown to the user in order to allow for performing each task on both of them. Along with this capability, the platform was entitled to keep track of the time spent to perform each task, to submit questionnaires, after each group of tasks, and collect their results. The time spent and the results of the questionnaire were used to perform analysis and plot graphs. This tool was tested with two pilot runs. The two testers involved in this case were a developer and a PhD in Human-Computer-Interaction, which gave important suggestions about the usability of the platform itself.

5.3 Results

In this paragraph are reported the results of the comparative evaluation. Before proceeding with the results it is important to state the nature of the test subjects. They were directly contacted among the members of our research group. The selection criteria was based on the fact that they were almost all users of the WordNet interface, thus they can be considered domain experts. The number of involved test subjects was 8, of those, 5 were PhD, 2 post-doc and a software engineer. Their answers in the form of Yes, No, or I don't know (IDK) were analyzed and plotted as bar graphs.

- Results display: the WordNet way of displaying results has been judged not easy to read and interpret. In particular, users have preferred the UKC way of displaying these in a table, using each single column to display a part of the result (gloss, example, concept Id, synset...). In this way, each element is easily identifiable.

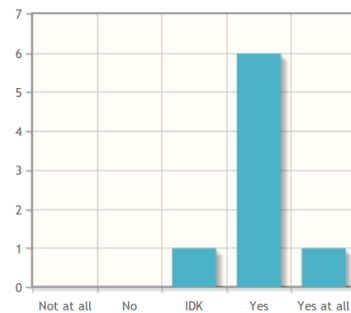

UKC Tabular View, is it intuitive?

- Results aggregation: with respect to the UKC, the WordNet view performs results aggregation over the data. In particular results are grouped according to their part of speech tag (POS). The UKC view includes all the results in the same table, thus the only way the user have to identify their type is to look at the POS-tag field or filter by POS or relation type. Indeed, more space that can be saved.

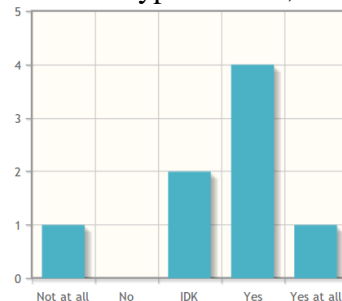

UKC DisplayManager, is it useful?

- Results relations: another important point involved in the analysis is the relation retrieval feature. By being a linguistic resource, the interface should provide the user access to the relations insisting on a concept in a way to easy the navigation among them. Under this point of view, the users have preferred the way the UKC interface manages relations retrieval and displaying. In particular the capability of filtering and interact with these, with respect to the fixed and link-based of WordNet, has been proven to be more flexible to the user needs.

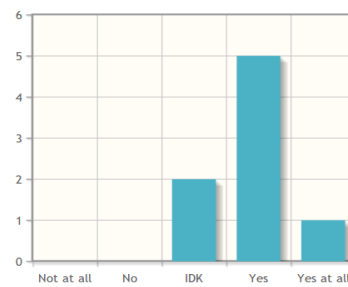

Is UKC relation retrieval approach more complete?

- Multilingual Results: the UKC has been proven to be more productive when it comes to mapping results in different languages with respect to WordNet. In particular, the former is able to retrieve the mapping of a results in each selected language, while the latter allows the user to retrieve results just in one language, namely losing the mapping implicit function.

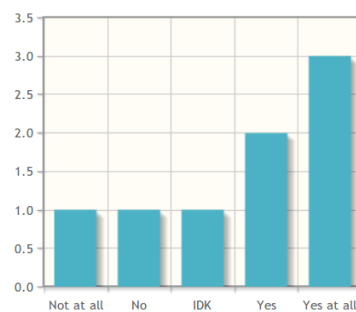

Multilingual WordNet, is it difficult?

- Missing history: beside these quantitative results, another important point got from some qualitative interviews, is the fact that both the interfaces do not keep track of the user's actions. Even though there was no task about it, users have reported this missing feature.

6. UKC-2 Platform

After the analysis reported in the previous section, the UKC design was refined in terms of user interactions and overall layout. The chosen approach is the one of a desktop environment in which multiple windows might be used at time. Each window is associated to an action, like a group of results of a search. Furthermore each window can be associated to a kind, which resembles the concept of sections of the previous interfaces. This choice was by two main reasons: (1) Having a multiple window layout helps in task in which more than one entity is needed, like in the case of comparisons or relations management. (2) Being able to minimize windows, the user can implicitly keep track of its actions, or can put in pause a task and continue with another one. The will allow to build a section-less system. As stated in the previous paragraph, the UKC-1 is divided into regions, each one assigned to a particular nature of given results, or to a kind of those. This approach has been demonstrated, by the analysis, to be distracting for the users. Indeed they usually have been losing the context when switching from one to another, in order to retrieve a given results. Other three main points that have contributed to the redesign of the user interface:

- Consistency of the representations: assign to each entity involved in the system a unique way of visualizing it, in order to maintain the consistency of the entities in different sections or scenarios of the application.
- Modularity of the interface: the system should adapt itself to what are the user's needs. By being able to modularize it, it would be possible for the user to customize it, in order to better fit his needs. It would also allow to fit particular scenarios of interaction by configuring it.
- Achievement of graphical methods for knowledge interaction: a part from the current interface, based on textual components like tables, snippets, tooltips and buttons, a second method of interaction would be based on shapes and colors, thus graphics. This is needed in a multilingual context like the one in which the UKC is set.

The new web client pursues the co-existence of two different kinds of interactions, textual and graphical on the same content pane, however in this paper only the textual one is discussed. The Textual User Interface was designed to resemble the current implementation of the UKC UI, proposing methods of interaction based on text input and forms. The TUI overall architecture (Figure-7) is composed of two different managers:

- Window Manager: this module is responsible of the creating and handling the different windows present in the interface. By using a modal windows based system, the users might interact with multiple entities at times, shown in different windows, each one customizable by the manager, on the base of the

user needs. For example, displaying multiple results at once, or comparing two similar elements.

- **Perspective Manager:** this component is used to provide transformation in data shown. The perspective is used to translate an entity between the four different available perspectives: natural language, formal language, E-Types and domains. The change of perspective is then made dynamic and applicable to each result (namely window) separately, such that the user will be aware of how a piece of knowledge changes in each point of view. Furthermore this will prevent the user to lose the context in which he is currently working. An example of change of perspective is given by the natural and formal language windows. In the first one, the concept is shown in relation with the synsets that lexicalize it in one or more given languages, while in the formal perspective (realized in the corresponding window) the same concept is shown in relation with other concepts (language independent).
- **UKC Web API Interface:** this module manages the communications between the front-end web client (running on the browser) and the data source available through a JSON API.

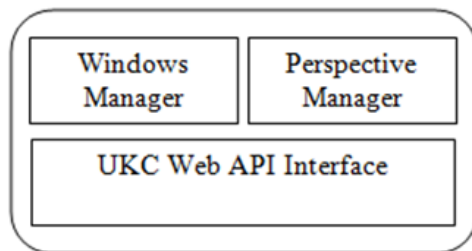

Figure-7: UCK-2 Overall Architecture

Other two main points in the new interface are the usage of a window system and the usage of colors to guide the user. The window choice is motivated by the will to provide the capability to perform multiple operations at time on the same dashboard, or in general, operations that involve multiple entities, like comparisons. Another point that can be elicited from Figure-8 above is the use of colors to indicate messages and sections. Each window, by being associated to a kind (natural, formal or eType) is displayed with a different color in the header. In this way the interface can implicitly guide the user through its sections without using labels. Furthermore, each window kind, in the new interface, represents a perspective. A perspective is a type of view over the data, and can be transformed from one to another. By doing this, the user does not lose the context while changing from a section to another.

In the new interface, colors are also used to communicate to the end user particular messages, like success, errors or warnings. A working demo of this new interface can be found at the address <http://uk.disi.unitn.it:3003>.

The screenshot shows the UKC-2 User Interface. At the top left is the UKC logo (Universal Knowledge Core). A search bar contains 'concepts:car'. The language is set to 'English'. A dropdown menu for 'Select Reference Language...' is open, showing options: Bengali, English, Hindi, Italian (selected), Mongolian, and Chinese. The main content area is titled 'Natural Language - car' and displays a table of results for the concept 'car'.

Rank	Synset	Gloss	Example	Concept ID
1	car; auto; automobile; machine; motorcar	a motor vehicle with four wheels	"he needs a car to get to work"; usually propelled by an internal combustion engine	15944
	it: auto; macchina; autovettura; vettura; automobile	veicolo a quattro ruote, con motore generalmente a scoppio, per il trasporto su strada di un numero limitato di persone	"è partito in macchina mezz'ora fa"; "alle dieci riusciamo finalmente a partire con una comoda macchina giapponese ed un timido autista zoppo"	
2	car; railcar; railway car; railroad car	a wheeled vehicle adapted to the rails of railroad	"three cars had jumped the rails"	15945
	it: automotrice; vettura	< NULL >		
3	cable car; car	a conveyance for passengers or freight on a cable railway	"they took a cable car to the top of the mountain"	15797
	it: cabina	< NULL >		
4	car; gondola	the compartment that is suspended from an airship and that carries personnel and the cargo and the power plant		15947
	it: navicella	< NULL >		

At the bottom of the interface, there is a 'car' tab, a footer with copyright information (© 2013 KIDF | News | Credits | IP Policy | Privacy statement | Term of use), and two buttons: 'Graphical' and 'Textual'.

Figure-8 UKC-2 User Interface Design

7. Related work

There are a small number of linguistic resources and lexical databases that exist today having web user interface. *WordNet* is a famous electronic lexical database of English nouns, verbs, adverbs, and adjectives grouped into a set of cognitive synonyms called synsets. WordNet lexical database was constructed and organized based on psycholinguistic principles related to theories of human mind lexical organizations. It was developed manually by a group of knowledge experts which was the main reason for its accuracy. *MultiWordNet* (<http://multiwordnet.fbk.eu>) and *EuroWordNet* (<http://www.iilc.uva.nl/EuroWordNet>) are multilingual lexical databases aligned with WordNet and structured in the same way as WordNet. They are considered as an extension to WordNet which resolve its multilingual drawback.

Both of these multilingual resources provide synsets which are strictly aligned with the WordNet English synsets and their semantic relations were imported from WordNet and preserved for the translated synsets.

BabelNet [Navigli, R. and Ponzetto, SP. (2010)] is a multilingual semantic network constructed automatically following a methodology that integrates lexicographic and encyclopedic knowledge from WordNet and Wikipedia. Its multilingual support was automatically constructed using machine translations in order to enrich their lexical representations. BabelNet wasn't constructed based on a formal representation. BabelNet provides a graphical user interface, known as BabelNetXplorer [Navigli, R. and Ponzetto, SP. (2012)]. BabelNetXplorer allows the users to visually explore the knowledge repository but maintaining and enriching the linguistic resource is not supported.

FrameNet [Baker, Collin F. et el. 1998 and Baker, Collin F. 2003] is lexical database of English has more than 10,000 word senses. It's machine-readable database, based on providing annotated examples of how words are used in actual texts. FrameNet is constructed based on a theory called Frame Semantics which assigns a semantic frame to each concept, i.e. a description explains the usage of the concept and its relations with other concept. FrameNet has been constructed manually by defining language independent frames and annotated examples. The multilingual lexicalization was done as separate projects. To the best of our knowledge, none of these tools has been built on a methodology for organizing knowledge obtained from multiple languages into natural language level and formal language level in order to facilitate extensibility and multicultural environment support. We could not also find a tool that has an advanced and user friendly interface that provides interactive and modular features for maintaining and enriching the knowledge base as UKC does.

Table-1 summarizes the set of basic feature supported by the existing and commonly used linguistic resources.

Linguistic Tool	Multilingual Resource	Distinction between Natural and Formal Languages	Manual Construction	Content Analysis Using Interactive User Interface	Content Enrichment Using Interactive User Interface
WordNet	No	No	Yes	Yes	No
MultiWordNet	Yes	No	Yes	Yes	No
EuroWordNet	Yes	No	Yes	Yes	Yes
BabelNet	Yes	No	No	Yes	No
FrameNet	Yes	Yes	Yes	Yes	No
UKC	Yes	Yes	Yes	Yes	Yes

Table 1: Comparison between UKC and the commonly used linguistic tools

8. Conclusion

The UKC web platform is an effective linguistic resource management tool that allows for knowledge organization in language-independent manner. The product shown in this paper has been a work in which the guidelines for an ideal/usable system have been set, along with its architecture, but the features yet to be implemented are considered as a part of the future work. Among these, the most important ones are described in the following paragraphs.

The Entity-Type and Domain perspectives which are entitled of displaying information about entity types (representation of real world phenomena) and how they are grouped to represent each of the different fields of the human knowledge. The pure Graphical User Interface that can be considered as one of the biggest expansion, since more than one perspective should be implemented in the form of interactions with a graphical representation of the knowledge base. This work would require a deep study of usability, involving users also in the design phase (i.e. participatory design).

Acknowledgement

The research leading to these results has received partially funding from the European Community's Seventh Framework Programme (FP7/2007-2013) under grant agreement n. 287704 CUBRIK: "Human-enhanced time-aware multimedia search.

We also would like to thank Maltese Vincenzo for all the contributions he made in the form of review, design suggestions and defect detection.

References

- [1] Baader, F., Calvanese, D., McGuinness, D. and Nardi, D. (2003). *The description logic handbook: Theory, implementation and applications*.
- [2] Baker, Collin F., Charles J. Fillmore, and Beau Cronin. (2003). The Structure of the FrameNet Database. *International Journal of Lexicography* 16 (3), 281-296, 149.
- [3] Baker, Collin F., Charles J. Fillmore, and John B. Lowe (1998). The Berkeley FrameNet project. *COLING-ACL '98: Proceedings of the Conference. Montreal, Canada 1998*. 86-90

- [4] Bodker, S. (2000). Scenarios in User-Centered Design - Setting the Stage for Reflection and Action. *Proceedings of the 32nd Annual Hawaii International Conference on Systems Sciences*.
- [5] Dutta, B., Giunchiglia, F. and Maltese, V. (2012). A facet-based methodology for geo-spatial modelling. *Journal on Data Semantics May 2012, Volume 1, Issue 1, pp 57-73*.
- [6] Eckle-Kohler, J., Gurevych, I., Hartmann, S., Matuschek M., and M. Meyer, C. (2012). UBY-LMF –A Uniform Format for Standardizing Heterogeneous Lexical-Semantic Resources in ISO-LMF. *In Proceedings of the 8th International Conference on Language Resources and Evaluation (LREC)*.
- [7] Fellbaum, C. (1998). WordNet: An Electronic Lexical Database. *Cambridge, MA: MIT Press*.
- [8] Ganbold, A., Farazi, F. and Giunchiglia, F. (2014). An Experiment in Managing Language Diversity Across Cultures. *The Sixth International Conference on Information, Process, and Knowledge Management*.
- [9] Giunchiglia, F. and Dutta, B. (2011). DERA: A Faceted Knowledge Organization Framework. *International Conference on Theory and Practice of Digital Libraries*.
- [10] Giunchiglia, F., Dutta, B. and Maltese, V. and Farazi, F. (2012a). A facet-based methodology for the construction of large-scale geospatial ontology. *Journal on Data Semantics (JoDS), Vol. 1, Issue 1 (2012), pp. 57-73*.
- [11] Giunchiglia, F., Marchese, M. and Zaihrayeu, I. (2005). Towards a theory of formal classification. *Journal on Data Semantics VIII Lecture Notes in Computer Science Volume 4380, 2007, pp 57-81*
- [12] Giunchiglia, F., Maltese, V., B. Dutta (2012b). Domains and Context: First steps towards managing diversity in knowledge. *Journal of Web Semantics (JWS) Vol 12 - 13 (2012): Special Issue: Reasoning with Context in the Semantic Web*.
- [13] Giunchiglia, F., Maltese, V., Farazi, F. and Dutta, B. (2010). GeoWordNet: a resource for geo-spatial applications. *Proceedings of the 7th Extended Semantic Web (ESWC)*
- [14] Gonzalez-Agirre, A., Laparra E., and Rigau G. (2012). Multilingual central repository version 3.0. *In Proceedings of the 8th International Conference on Language Resources and Evaluation (LREC), pages 2525–2529*.
- [15] Gutiérrez, Y and Orquín, A. (2011). Enriching the Integration of Semantic Resources based on WordNet. *Procesamiento del Lenguaje Natural, vol. 47, pp. 249-257*.
- [16] Katifori, A., Halatsis, C., Lepouras, G., Vassilakis, C. and Giannopolou E. (2007). Ontology visualization methods - a survey. *Journal on ACM Computing Surveys (CSUR) Surveys Homepage archive*

Volume 39 Issue 4, Article No. 10

- [17] Koeva, S., Mihov, S. and Tinchev, T. (2004). Bulgarian Wordnet - structure and validation. *Romanian Journal of Information Science and Technology* 7(1-2) (2004) 61-78.
- [18] Miller, George A. (1995). WordNet: A Lexical Database for English. *Communications of the ACM* Vol. 38, No. 11: 39-41.
- [19] Navigli, R. and Ponzetto, SP. (2010) BabelNet: Building a very large multilingual semantic network. *Proceedings of the 48th Annual Meeting of the Association for Computational Linguistics, Uppsala, Sweden, 11–16 July 2010, pp. 216–225.*
- [20] Navigli, R. and Ponzetto, SP. (2012) BabelNetExplorer: A Platform for Multilingual Lexical Knowledge Base Access and Exploration. *Proceedings of International World Wide Web Conference (IW3C2), Lyon, France, 16-20 April 2012.*