

# Wearable non-invasive blood glucose monitor system based on galvanic skin resistance measurement

Massimo Donelli,<sup>1,4,✉</sup> Giuseppe Espa,<sup>2,4</sup> Paola Feraco,<sup>3</sup> and Mohammedhusen Manekiya<sup>1</sup>

<sup>1</sup>Department of Information Engineering and Computer Science, University of Trento, Trento, Italy

<sup>2</sup>Department of Economy and Management, University of Trento, Trento, Italy

<sup>3</sup>Azienda provinciale per i servizi sanitari, Trento, Italy

<sup>4</sup>Center for Security and Crime Sciences, University of Trento and University of Verona, Trento and Verona, Italy

✉ Email: massimo.donelli@unitn.it

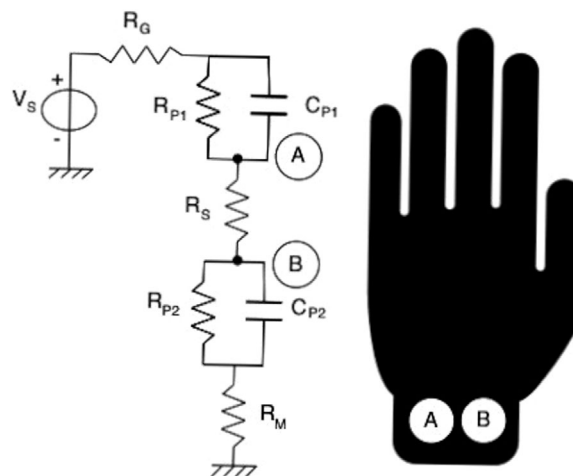

Fig. 1 Schema of galvanic skin resistance measurement

This work proposes a wearable system for the non-invasive measurement of the blood glucose level. In particular, the blood glucose variations are related with the skin resistance measured with a suitable sensor. A microcontroller is aimed to measure, store and transmits on a wireless channel, the blood glucose level in a simple, non-invasive and unsupervised way. The system is particularly useful to monitoring the glucose level in diabetic patients, and to perform the oral glucose tolerance test (OGTT) useful to identify metabolic diseases and to diagnose diabetes mellitus in the early stage. The preliminary obtained results are quite promising and demonstrated the potentialities of the device as diagnostic and home care tool.

**Introduction:** Diabetes is a type a chronic metabolic diseases characterized by a drastic increase of the blood glucose level from its normal level. The abnormal increase of the blood sugar level is due to an inadequate production of insulin in blood cells, to an improper response of body cells to the insulin or both the reasons. Type two diabetes is the most common type and it is also called Diabetes Mellitus and it affects a wide range of people globally [1, 2]. Long-term diabetes complications include stroke, damage to the kidneys, nerves and eyes, and other cardiovascular diseases. An early detection of diabetes has great importance to prevent or to limit the effects of the various serious complications. Most people with affected by type 2 diabetes have evidence of the so called pre-diabetes. The progression of pre-diabetes to the type two diabetes can be slowed or reversed by adopting healthy lifestyle changes or suitable medications aimed to improve insulin sensitivity or limit the liver glucose production. A major problem faced by diabetic patients is an anomalous variation of blood glyceic levels. In particular, the glyceic levels may fluctuate abnormally leading to hyper or hypoglycemic events, often without notice, with high risk of death for the patient. Hence regular monitoring of glucose level is mandatory to prevent serious compliances. To properly control diabetes the blood glucose monitoring must be continuously measured. The available blood glucose monitors are not able to determine the real-time blood glucose level, they are quite invasive since they make use of needles to extract blood samples. Moreover, they require expensive chemical strips to properly operate. Due to the invasive and painful measure, some patients (especially pediatric patients) often try to avoid measuring their glucose levels. There is an urgent need to develop low cost, non-invasive monitoring tools able to measure the glucose blood level and to identify patients with early pre-diabetic conditions, particularly those residing in poor and emerging nations, where people have limited or no access to hospitals and other medical facilities. Some researchers demonstrated how to measure the blood glucose level, non-invasively by using near infrared (NIR) [3, 4] optical technique which overcomes the problems in invasive measurement, like fingering puncturing. The problem of such kind of NIR sensors is that they are quite sensitive to the finger pressure applied during the measurement that can lead to wrong measurements. Recently, a direct correlation between the galvanic skin resistance and the blood glucose level has been discovered [5–7]. The sensor measuring the galvanic skin resistance is quite simple and not critical or influenced by other factors, some commercial prototypes are available in the mar-

ket as biomedical devices, but they are expensive and bulky. In the last decades, our to the strong miniaturization of microcontrollers and sensors, there has been a big diffusion of wearable compact sensors able to monitor in real time different biomedical parameters [8, 9]. The aim of this research is to propose a low cost non-invasive wearable sensor able to measure the blood glucose level by using the galvanic skin resistance. A prototype has been developed fabricated and experimentally assessed obtaining promising results.

**Sensors and measurement description:** Galvanic skin resistance (GSR) can be recorded between two electrodes placed on the hand, by using a feeble electric current (few micro amperes) running between them. The GSR can be measured by using a direct (DC) or an alternating (AC) current, through a circuit consisting of a voltmeter, electric battery and subject to measure changes in electrodermal activity EDA; however, DC currents are used more often than AC current for measuring the blood glucose level [6]. The schema of measurement system and the circuital model of the two electrodes are reported in Figure 1. The following relation report the voltages measured by the voltmeter that permit to estimate the GSR and consequently the blood glucose level:

$$V_{GSR}(\alpha) = V_s \frac{R_M}{\frac{1}{R_{P1} + \frac{1}{j\omega C_{P1}}} + R_s(\alpha) + \frac{1}{R_{P2} + \frac{1}{j\omega C_{P2}}} + R_M} \quad (1)$$

where  $V_s$  is the voltage generator (3.3 V),  $\alpha$  is the glucose blood level,  $R_{P1}$ ,  $C_{P1}$  and  $R_{P2}$ ,  $C_{P2}$  are the electrode contact points resistances and capacitances respectively.  $R_s$  is the measured skin resistance and  $R_m = 470K\Omega$ . An analogic to digital (ADC) converter is used to measure the voltage amplitude across the resistance  $R_m$ . Considering that the measure is performed with DC current and the electrodes present very low resistance,  $R_{P1}$ ,  $R_{P2}$ ,  $C_{P1}$  and  $C_{P2}$  can be approximated to zero and the GSR can be easily estimated with the following relation:

$$R_s(\alpha) = \frac{R_M(V_s - V_{GSR}(\alpha))}{V_{GSR}(\alpha)} \quad (2)$$

The system is equipped with a ESP32-beetle micro-controller particularly suitable for wearable application. The ESP32 module is equipped with a WiFi card, a bluetooth and different analogic to digital converter (ADC) channels. The power supply is provided by means of a 3.3 V button battery. All the system is inserted into a plastic case fabricated with a 3D printer, for the sake of safety an antibacterial filament has been used. The system dimensions are comparable with those of a standard watch.

**Experimental assessment:** In this section, the proposed technique has been experimental assessed by measuring the glyceic curve of different subjects. In particular, the glyceic curve of 20 voluntary subject have been measured with a standard glucose meter (the model INR Coaguchek InRange, Roche company) based on blood samples. The

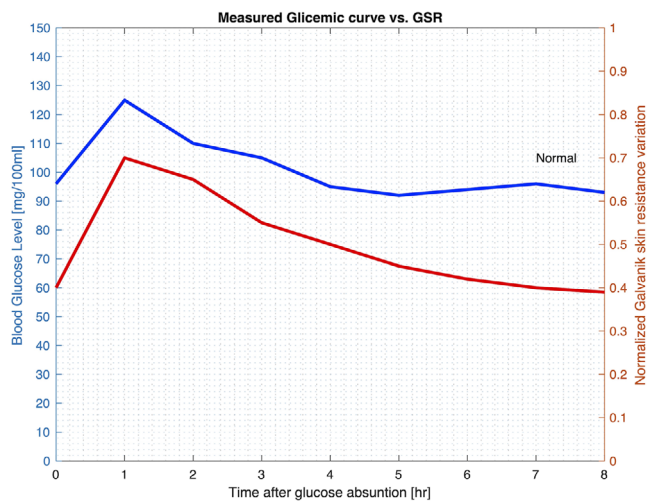

**Fig. 2** Behaviour of blood glucose level and galvanic skin resistance versus time

measures have been compared with the proposed GSR sensor. In healthy people, the body produces a certain amount of insulin when glucose enters the bloodstream. Insulin prevents glucose from exceeding the maximum tolerated level by the body, beyond which the excess dose is stored in the liver. Exceeding this threshold indicates impaired glucose tolerance (IGT or 'impaired glucose tolerance'), hence an initial relative insulin deficiency which could lead to diabetes. The glycemic curve is a clinical test carried out to evaluate the metabolism of carbohydrates and identify its alterations. Also referred to OGTT, the glycemic curve measures the concentration of sugars in blood, before and after the oral administration of a certain amount of sugar solution. The glycemic curve is a test that is performed to understand if the concentration of glucose in the blood is within the normal range. Therefore, the test is useful for screening and diagnosing diabetes and pre-diabetes, as well as allowing the monitoring of patients with high (hyperglycemia) or low (hypoglycemia) blood glucose. If the glucose curve test shows after the post-ingestion of glucose, values between 140 and 200 mg/dl and the fasting levels are between 110 and 126 mg/dl, the alteration is identified as 'impaired glucose tolerance'. This medical condition is of fundamental importance, since, although it has not yet evolved into diabetes mellitus, it still presents characteristics of problems that must be appropriately addressed. A very useful test for defining the diagnosis of diabetes in the presence of equivocal data is the so-called oral glucose load test. This test is based on the administration by mouth of a fixed quantity of glucose in aqueous solution, followed by some small blood samples at pre-established time intervals. These samples are necessary for the determination of glycemic curve (trend of blood glucose concentration). The oral glucose tolerance test must be performed with the administration of 75 grams of glucose in 250 – 300 mL of water, within a period of time ranging from 30 seconds up to 5 min (in the child, or in the patient weighing less than 43 kg, the glucose dose will be equal to 1, 75 g per kg of weight). Blood samples are taken every hour, the finding of glycemia higher than 200 mg/dL after 2 h of the glucose load administration, indicates (if confirmed a second time) the presence of diabetes mellitus even if the fasting glycemia is less than 126 mg/dL. Figure 2 reports the measure of glycemic curve after the administration of glucose solution. The sample time has been set to measure GSR every hour, con-

tinuously for 8 h. After the measurement campaign, data are transmitted with the bluetooth to a personal computer for further elaboration or storage. As it can be noticed from the data of Figure 2 the blood glucose level come back to normal values after about 1 h. The GSR curve follows exactly the behaviour of glucose level, the peak of GSR is located in the same time positions of the glucose level. The collected data, for all the considered subjects (only one subject is reported due to space constraints) demonstrated the correlation between GSR and blood glucose level.

**Conclusion:** This work proposed a non-invasive system based on the measurement of galvanic skin resistance and the system was experimentally assessed to measure the glucose blood level. The sensor has been integrated into a wearable bracelet equipped with a microcontroller aimed to measure, store and send the data through a wireless channel in real time. The obtained results are quite good and demonstrate the potentiality of such device as efficient tool for the early diagnosis of level two diabetes and to monitoring the glucose blood levels in diabetes patients.

**Acknowledgements:** The authors want to thank Dr. E. Bortolotti for the revision of the manuscript.

© 2021 The Authors. *Electronics Letters* published by John Wiley & Sons Ltd on behalf of The Institution of Engineering and Technology

This is an open access article under the terms of the Creative Commons Attribution License, which permits use, distribution and reproduction in any medium, provided the original work is properly cited.

Received: 8 June 2021 Accepted: 20 August 2021

doi: 10.1049/ell2.12315

## References

- 1 Alsuliman, M.A., Alotaibi, S.A., Zhang, Q., Durgampudi, P.K.: A systematic review of factors associated with uncontrolled diabetes and meta-analysis of its prevalence in Saudi Arabia since 2006. *Diabetes Metab. Res. Rev.* **37**(3) e3395 (2021)
- 2 Wagner, K.-H., Schwingshackl, L., Draxler, A., Franzke, B.: Impact of dietary and lifestyle interventions in elderly or people diagnosed with diabetes, metabolic disorders, cardiovascular disease, cancer and micronutrient deficiency on micronuclei frequency—A systematic review and meta-analysis. *Mutat. Res./Rev. Mutat. Res.* **787**, 108367 (2021)
- 3 Das, T., Ghosh, A., Guha, S., Basak, P.: Early detection of diabetes based on skin impedance spectrogram and heart rate variability noninvasively. In: 1st International Conference on Electronics, Materials Engineering and Nano-Technology (IEMENTech), Kolkata, India. pp. 1–5. (2017)
- 4 Narkhede, P., Dhalwar, S., Karthikeyan, B.: NIR based non-invasive blood glucose measurement. *Indian J. Sci. Technol.* **2016**, 9(41) (2016)
- 5 Petrofsky, J.S., McLellan, K.: Galvanic skin resistance—A marker for endothelial damage in diabetes. *Diabetes Technol. Ther.* **11**(7), 461–467
- 6 Khalfallah, K., Ayoub, H., Calvet, J.H., Neveu, X., Brunswick, P., Griveau, S., Lair, V., Cassir, M., Bedioui, F.: Noninvasive galvanic skin sensor for early diagnosis of sudomotor dysfunction: Application to diabetes. *IEEE Sens. J.* **12**(3), 456–463
- 7 Freedman, B.I., Bowden, D.W., Smith, S.C., Xu, J., Divers, J.: Relationships between electrochemical skin conductance and kidney disease in Type 2 diabetes. *J. Diabetes Complications* **28**(1), 56–60 (2014)
- 8 Manekiya, M., Donelli, M.: Monitoring the COVID-19 diffusion by combining wearable biosensors and smartphones. *Prog. Electromagn. Res. M* **100**, 13–21 (2021)
- 9 Mukhopadhyay, S.C.: Wearable sensors for human activity monitoring: A review. *IEEE Sens. J.* **15**(3), 1321–1330 (2015)